

Carbide Miniature End Mill

EPDBE-PN/ATH *EPDSE-PN/ATH*

Epoch Deep Evolution series



MOLDINO Tool Engineering, Ltd.

New Product News | No.1110E-10 | 2022-12

Features 01 Features of Epoch Deep Evolution

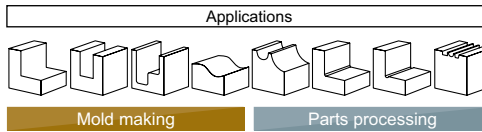
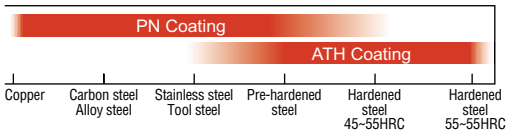

EPDBE-ATH/PN
R0.05~R3 [164 Items×2]

EPDSE-ATH/PN
φ0.1~φ6 [145 Items×2]

Flute shape increases resistance to breakage.

Epoch Deep Ball Evolution



High-strength flute shape with high chip removal characteristics. Stronger R flute helix angle improves cutting performance.



Tool : EPDBE2010-10-ATH
(R0.5 Under neck 10mm)

0.02mm Finishing surface
Incline angle : 1°

Work material: SUS420J2 (H) 52HRC
Holder : HSK-F63
Coolant : Air Blow
 $n=16,000\text{min}^{-1}$ ($v_c=50.2\text{m/min}$)
 $v_f=1000\text{mm/min}$ ($f_z=0.03\text{mm/t}$)
 $a_p \times a_e=0.02\text{mm} \times 0.02\text{mm}$
OH=18mm

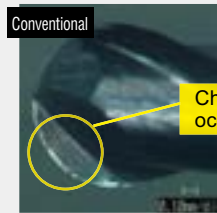

Epoch Deep Square Evolution



Cutting edge with high chipping strength and high cutting performance provides improved stability.

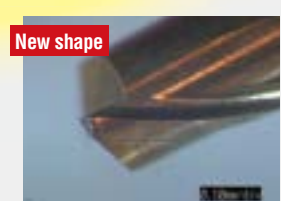

Tool : EPDSE2010-4-ATH
(φ1 Under neck 4mm)

1.5mm square island
(90° standing walls)

Work material : HPM-MAGIC 40HRC
Holder : HSK-F63
Coolant : Wet
 $n=15,000\text{min}^{-1}$ ($v_c=47\text{m/min}$)
 $v_f=1,000\text{mm/min}$ ($f_z=0.03\text{mm/t}$)
 $a_p \times a_e=0.1\text{mm} \times 0.1\text{mm}$

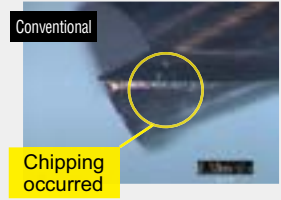

Improved compound neck shape

- Further improves the conventional compound shape of R and taper to both resist breakage and suppress deflection.
- ※Since the actual effective under-neck length is shorter than the conventional Deep Series, be sure to check the interference region before use.

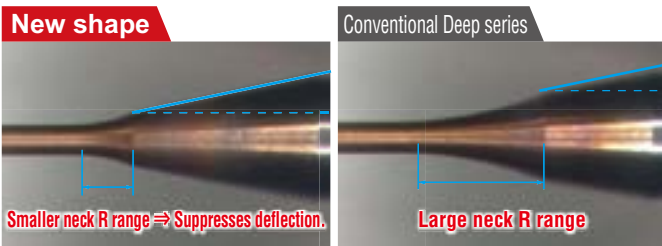

[Caution]

The interference region has changed due to changes in the neck shape. Be sure to check for interference before starting machining.

Static load test results

Testing tool size
φ1×Under neck 6

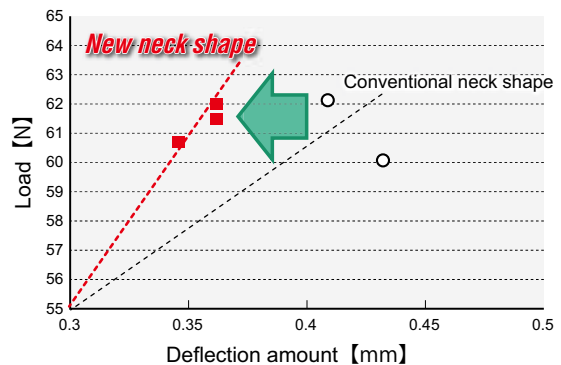

Deflection suppression effect is high even under the same load. Enables machining with even higher accuracy.

Abundant lineup

Ball End Mill 164 PN/ATH Items×2 Total 618 items

Square End Mill 145 PN/ATH Items×2 Total 618 items

EPDBE-PN ← EPDB EPDB-TH (Stocked by specified distributor)

EPDSE-PN ← EPDS EPDS-TH (Stocked by specified distributor)

Features

- A heat-resistant coating material with excellent adhesion to the tool substrate was achieved by optimizing the Al content.
- Exhibits with good wear resistance due to Si doping to the AlCr coating layer.
- Exhibits excellent cutting life for cutting materials such as plastic molds, etc. where tool seizure often occurs. (2x the cutting life compared to conventional products.)
Provides the long life in cutting processing of materials starting with HPM-MAGIC and including prehardened steel, carbon steel, alloy steel, SUS, SKD61, SKD11, etc.
- By improving heat resistance, long life are possible for both wet cutting and **dry cutting**.
Note) This product obtains less electric conductivity. Therefore, Please caution of using electric transmitted measuring systems.

Characteristics

Adhesion of PN Coating

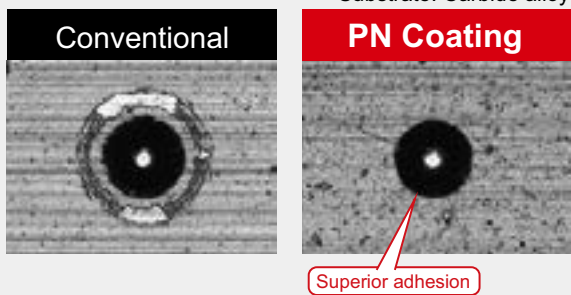

Cross-section photograph of PN Coating layer structure

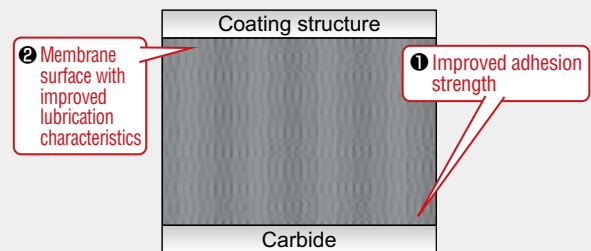

Features

- Hardness and oxidation resistance of TH Coating is further improved. Enables longer life and higher efficient when cutting high-hardness materials.
(Si nano composite coating with finer crystal particles)
- Exhibits amazing performance when cutting high-hardness materials (55HRC or higher)
Cold-worked die steel, HSS, tool steel.
- Long life for both dry cutting and wet cutting

Line Up

Epoch Deep Ball Evolution

EPDBE-PN

PN Coating

2 Flutes

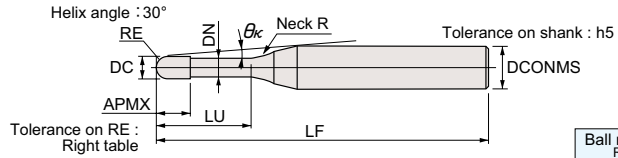

(mm)	
Ball radius RE	Tolerance on RE
RE ≤ 0.25	±0.003
0.25 < RE	±0.005

EPDBE2-0.05-0.1-0.15-0.2-0.25-0.3-0.4-0.5-0.6-PN

Item code	Stock PN	Size (mm)										The effective under-neck length for the various draft angles										
		Ball radius RE	Tool dia. DC	Under neck length LU	Flute length APMX	Neck dia. DN	Overall length LF	Shank dia. DCONMS	Neck R	Interference angle θ_K	0.5°	1°	1.5°	2°	3°							
		EPDBE2001-0.2-PN	●	0.05	0.1	0.2	0.08	0.08	45	4	1	11.76	0.35	0.37	0.39	0.41	0.44					
EPDBE2001-0.3-PN	●	0.3	11.64			0.46						0.48	0.50	0.52	0.57							
EPDBE2001-0.5-PN	●	0.5	11.40			0.67						0.70	0.73	0.76	0.81							
EPDBE2002-0.5-PN	●	0.1	0.2	0.5	0.15	0.17	50	4	1	11.42	0.70	0.72	0.75	0.77	0.82							
EPDBE2002-0.75-PN	●			0.75						11.13	0.96	0.99	1.02	1.05	1.11							
EPDBE2002-1-PN	●			1						10.86	1.22	1.26	1.30	1.33	1.39							
EPDBE2002-1.25-PN	●			1.25						10.60	1.48	1.52	1.57	1.61	1.72							
EPDBE2002-1.5-PN	●			1.5						10.35	1.74	1.79	1.84	1.88	2.05							
EPDBE2002-2-PN	●			2						9.88	2.25	2.32	2.37	2.45	2.71							
EPDBE2002-2.5-PN	●			2.5						9.46	2.77	2.84	2.91	3.05	3.37							
EPDBE2002-3-PN	●			3						9.07	3.28	3.37	3.48	3.65	4.04							
EPDBE2003-0.5-PN	●			0.15						0.3	0.5	0.25	0.27	50	4	2	11.47	0.78	0.82	0.86	0.90	0.98
EPDBE2003-0.75-PN	●										0.75						11.17	1.05	1.10	1.15	1.20	1.29
EPDBE2003-1-PN	●	1	10.89		1.31	1.38	1.43	1.49	1.59													
EPDBE2003-1.25-PN	●	1.25	10.62		1.58	1.65	1.72	1.78	1.89													
EPDBE2003-1.5-PN	●	1.5	10.36		1.84	1.92	1.99	2.06	2.18													
EPDBE2003-2-PN	●	2	9.88		2.36	2.46	2.55	2.62	2.76													
EPDBE2003-2.5-PN	●	2.5	9.45		2.89	3.00	3.10	3.18	3.36													
EPDBE2003-3-PN	●	3	9.05		3.41	3.53	3.64	3.73	4.02													
EPDBE2004-0.75-PN	●	0.2	0.4		0.75	0.3	0.37	50	4		2						11.21	1.04	1.09	1.14	1.19	1.28
EPDBE2004-1-PN	●				1												10.91	1.31	1.37	1.43	1.48	1.58
EPDBE2004-1.5-PN	●			1.5	10.37					1.84		1.92	1.99	2.06	2.17							
EPDBE2004-2-PN	●			2	9.88					2.36		2.46	2.54	2.62	2.75							
EPDBE2004-2.5-PN	●			2.5	9.43					2.89		3.00	3.09	3.18	3.34							
EPDBE2004-3-PN	●			3	9.03					3.41		3.53	3.63	3.73	4.01							
EPDBE2004-3.5-PN	●			3.5	8.65					3.93		4.06	4.18	4.27	4.67							
EPDBE2004-4-PN	●			4	8.30					4.45		4.59	4.71	4.83	5.33							
EPDBE2004-4.5-PN	●			4.5	7.99					4.97		5.12	5.25	5.43	6.00							
EPDBE2005-1-PN	●			0.25	0.5					1		0.35	0.47	50	4	2	10.94	1.31	1.37	1.42	1.47	1.57
EPDBE2005-1.5-PN	●	1.5	10.39			1.83	1.91	1.98	2.05	2.17												
EPDBE2005-2-PN	●	2	9.88			2.36	2.45	2.54	2.61	2.75												
EPDBE2005-2.5-PN	●	2.5	9.42			2.88	2.99	3.09	3.17	3.33												
EPDBE2005-3-PN	●	3	9.00			3.41	3.53	3.63	3.72	3.99												
EPDBE2005-4-PN	●	4	8.27			4.45	4.59	4.71	4.82	5.32												
EPDBE2005-5-PN	●	5	7.64			5.48	5.65	5.78	6.01	6.65												
EPDBE2005-5.5-PN	●	5.5	7.36			6.00	6.17	6.31	6.61	7.31												
EPDBE2005-6-PN	●	6	7.10			6.52	6.70	6.88	7.21	7.97												
EPDBE2005-8-PN	●	8	6.23			8.58	8.79	9.16	9.60	10.63												
EPDBE2006-1-PN	●	0.3	0.6	1	0.4	0.57	50	4	4	10.98	1.44	1.54	1.63	1.71	1.88							
EPDBE2006-2-PN	●			2						9.88	2.52	2.66	2.79	2.91	3.13							
EPDBE2006-2.5-PN	●			2.5						9.41	3.05	3.22	3.36	3.49	3.73							
EPDBE2006-3-PN	●			3						8.98	3.58	3.77	3.93	4.07	4.32							
EPDBE2006-3.5-PN	●			3.5						8.58	4.12	4.32	4.49	4.64	4.91							
EPDBE2006-4-PN	●			4						8.22	4.64	4.86	5.04	5.20	5.48							
EPDBE2006-4.5-PN	●			4.5						7.89	5.17	5.40	5.59	5.76	6.06							
EPDBE2006-5-PN	●			5						7.59	5.70	5.94	6.14	6.32	6.63							
EPDBE2006-5.5-PN	●			5.5						7.31	6.22	6.48	6.69	6.87	7.29							
EPDBE2006-6-PN	●			6						7.04	6.75	7.02	7.23	7.42	7.96							
EPDBE2006-7-PN	●			7						6.57	7.79	8.08	8.32	8.52	9.28							
EPDBE2006-8-PN	●			8						6.16	8.84	9.15	9.40	9.61	10.61							
EPDBE2006-9-PN	●			9						5.79	9.88	10.21	10.47	10.79	11.94							
EPDBE2006-10-PN	●			10						5.47	10.92	11.26	11.54	11.99	13.27							
EPDBE2006-12-PN	●	12	4.92	12.99	13.37	13.72	14.38	15.92														

● : Stocked items.

Detailed shape below neck

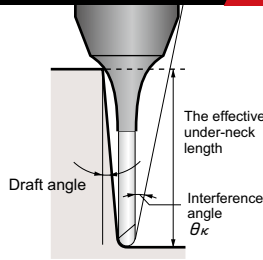
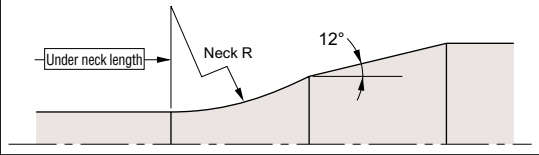

[Note]

The effective under-neck length is different from Epoch Deep Ball EPDB. Please recheck the interference region.

EPDBE2-0.35-0.4-0.5-0.6-0.7-0.8-0.9-PN

Item code	Stock PN	Size (mm)									The effective under-neck length for the various draft angles				
		Ball radius	Tool dia.	Under neck length	Flute length	Neck dia.	Overall length	Shank dia.	Neck R	Interference angle	0.5°	1°	1.5°	2°	3°
		RE	DC	LU	APMX	DN	LF	DCONMS	θκ						
EPDBE2007-2-PN	●	0.35	0.7	2	0.45	0.67	50	4	4	9.88	2.52	2.66	2.79	2.90	3.12
EPDBE2007-4-PN	●			4						8.18	4.64	4.86	5.04	5.20	5.48
EPDBE2007-6-PN	●			6						6.98	6.74	7.01	7.23	7.42	7.94
EPDBE2007-8-PN	●			8						6.09	8.83	9.14	9.39	9.61	10.60
EPDBE2008-2-PN	●	0.4	0.8	2	0.5	0.77	50	4	4	9.87	2.51	2.65	2.78	2.89	3.11
EPDBE2008-4-PN	●			4						8.14	4.64	4.85	5.03	5.19	5.47
EPDBE2008-5-PN	●			5						7.48	5.69	5.93	6.13	6.31	6.61
EPDBE2008-6-PN	●			6						6.92	6.74	7.01	7.23	7.41	7.92
EPDBE2008-8-PN	●			8						6.01	8.83	9.14	9.39	9.60	10.58
EPDBE2008-10-PN	●	10	5.32	10.91	11.26	11.53	11.97	13.23							
EPDBE2009-2-PN	●	0.45	0.9	2	0.6	0.87	50	4	4	9.87	2.51	2.65	2.77	2.89	3.10
EPDBE2009-4-PN	●			4						8.09	4.64	4.85	5.03	5.18	5.46
EPDBE2009-6-PN	●			6						6.85	6.74	7.00	7.22	7.41	7.91
EPDBE2009-8-PN	●			8						5.94	8.83	9.14	9.38	9.60	10.56
EPDBE2010-2-PN	●	0.5	1	2	0.8	0.96	50	4	4	9.84	2.54	2.67	2.79	2.90	3.11
EPDBE2010-3-PN	●			3						8.84	3.61	3.78	3.93	4.06	4.30
EPDBE2010-4-PN	●			4						8.02	4.66	4.87	5.04	5.20	5.47
EPDBE2010-5-PN	●			5						7.34	5.72	5.95	6.14	6.31	6.61
EPDBE2010-6-PN	●			6						6.77	6.76	7.02	7.23	7.42	7.92
EPDBE2010-7-PN	●			7						6.28	7.81	8.09	8.32	8.52	9.25
EPDBE2010-8-PN	●			8			5.85	8.85	9.15	9.40	9.61	10.58			
EPDBE2010-9-PN	●			9			5.48	9.89	10.21	10.47	10.78	11.91			
EPDBE2010-10-PN	●			10			5.15	10.93	11.27	11.54	11.98	13.23			
EPDBE2010-12-PN	●			12			4.60	13.00	13.37	13.72	14.37	15.89			
EPDBE2010-13-PN	●			13			4.37	14.04	14.42	14.86	15.57	17.21			
EPDBE2010-14-PN	●			14			4.16	15.07	15.47	16.00	16.76	18.54			
EPDBE2010-16-PN	●	16	3.79	17.13	17.56	18.28	19.16	21.20							
EPDBE2010-18-PN	●	18	3.49	19.19	19.66	20.56	21.55	23.85							
EPDBE2010-20-PN	●	20	3.23	21.25	21.84	22.84	23.94	26.51							
EPDBE2011-2-PN	●	0.55	1.1	2	1	1.05	50	4	4	9.81	2.58	2.70	2.81	2.92	3.12
EPDBE2011-4-PN	●			4						7.95	4.69	4.89	5.06	5.21	5.48
EPDBE2011-6-PN	●			6						6.68	6.79	7.04	7.25	7.43	7.94
EPDBE2011-8-PN	●			8						5.76	8.87	9.17	9.41	9.61	10.59
EPDBE2011-10-PN	●	10	5.06	10.95	11.28	11.55	12.00	13.25							
EPDBE2012-4-PN	●	0.6	1.2	4	1.1	1.15	50	4	4	7.89	4.69	4.88	5.05	5.20	5.47
EPDBE2012-6-PN	●			6						6.60	6.79	7.03	7.24	7.42	7.92
EPDBE2012-8-PN	●			8						5.67	8.87	9.16	9.40	9.61	10.58
EPDBE2012-10-PN	●			10			4.97	10.95	11.28	11.54	11.99	13.23			
EPDBE2012-12-PN	●			12			4.43	13.02	13.38	13.73	14.38	15.89			
EPDBE2014-8-PN	●	0.7	1.4	8	1.3	1.34	50	4	4	5.48	8.89	9.18	9.41	9.61	10.58
EPDBE2014-12-PN	●			12			4.24			13.04	13.39	13.74	14.39	15.89	
EPDBE2014-16-PN	●			16			3.46			17.16	17.57	18.31	19.17	21.20	
EPDBE2015-4-PN	●	0.75	1.5	4	1.35	1.44	50	4	4	7.68	4.71	4.89	5.06	5.20	5.46
EPDBE2015-6-PN	●			6						6.33	6.81	7.04	7.25	7.42	7.91
EPDBE2015-8-PN	●			8						5.39	8.89	9.17	9.41	9.61	10.56
EPDBE2015-10-PN	●			10						4.68	10.96	11.29	11.55	11.98	13.22
EPDBE2015-12-PN	●			12			4.14	13.03	13.39	13.74	14.38	15.87			
EPDBE2015-14-PN	●			14			3.72	15.10	15.48	16.02	16.77	18.52			
EPDBE2015-16-PN	●			16			3.77	17.16	17.57	18.30	19.16	21.18			
EPDBE2015-18-PN	●			18			3.08	19.22	19.69	20.58	21.56	23.83			
EPDBE2015-20-PN	●	20	2.84	21.27	21.87	22.86	23.95	No interference							
EPDBE2016-8-PN	●	0.8	1.6	8	1.4	1.54	50	4	4	5.28	8.89	9.17	9.40	9.60	10.55
EPDBE2016-12-PN	●			12			4.05			13.03	13.39	13.73	14.37	15.85	
EPDBE2016-16-PN	●			16			3.28			17.16	17.57	18.29	19.15	21.16	
EPDBE2016-20-PN	●			20			2.75			21.27	21.87	22.86	23.94	No interference	
EPDBE2018-8-PN	●	0.9	1.8	8	1.6	1.73	50	4	4	5.06	8.91	9.18	9.41	9.61	10.54
EPDBE2018-12-PN	●			12			3.83			13.05	13.40	13.74	14.38	15.85	
EPDBE2018-16-PN	●			16			3.09			17.17	17.58	18.31	19.16	21.16	
EPDBE2018-20-PN	●			20			2.58			21.28	21.88	22.87	23.95	No interference	

Features
Dimensions
Ball/PN Coating
Dimensions
Ball/ATH Coating
Cutting condition
Ball/High efficiency
Cutting condition
Ball/High accuracy
Dimensions
Square/PN Coating
Dimensions
Square/ATH Coating
Cutting condition
Square/High efficiency
Cutting condition
Technical Data

Line Up

Epoch Deep Ball Evolution

EPDBE-PN

PN Coating

2 Flutes

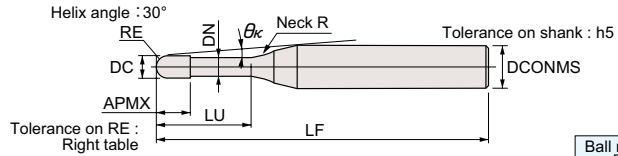

EPDBE2000-00.00-PN

(mm)	
Ball radius RE	Tolerance on RE
RE ≤ 0.25	±0.003
0.25 < RE	±0.005

Item code	Stock PN	Size (mm)										The effective under-neck length for the various draft angles				
		Ball radius RE	Tool dia. DC	Under neck length LU	Flute length APMX	Neck dia. DN	Overall length LF	Shank dia. DCONMS	Neck R	Interference angle θκ	0.5°	1°	1.5°	2°	3°	
																10.5°
EPDBE2020-3-PN	●	1	2	3	1.7	1.92	50	4	4	8.26	3.71	3.84	3.96	4.07	4.29	
EPDBE2020-4-PN	●			4						7.23	4.75	4.92	5.07	5.21	5.45	
EPDBE2020-6-PN	●			6						5.78	6.84	7.07	7.26	7.43	7.89	
EPDBE2020-8-PN	●			8						4.81	8.92	9.19	9.42	9.61	10.54	
EPDBE2020-10-PN	●			10			4.12			11.00	11.30	11.56	11.99	13.20		
EPDBE2020-12-PN	●			12			3.61			13.06	13.41	13.76	14.39	15.85		
EPDBE2020-13-PN	●			13			3.39			14.10	14.45	14.90	15.58	17.18		
EPDBE2020-14-PN	●			14			3.20			15.13	15.50	16.04	16.78	18.51		
EPDBE2020-16-PN	●			16			2.88			17.19	17.59	18.32	19.17	No interference		
EPDBE2020-18-PN	●			18			2.62			19.24	19.72	20.60	21.57	No interference		
EPDBE2020-20-PN	●			20			2.40			21.30	21.90	22.88	23.96	No interference		
EPDBE2020-22-PN	●			22			2.22			23.35	24.08	25.16	26.35	No interference		
EPDBE2020-25-PN	●			25			1.99			26.42	27.35	28.58	No interference	No interference		
EPDBE2020-30-PN	●			30			1.70			31.53	32.80	34.29	No interference	No interference		
EPDBE2020-35-PN	●			35			1.48			36.65	38.24	No interference	No interference	No interference		
EPDBE2020-40-PN	●			40			1.31			41.86	43.69	No interference	No interference	No interference		
EPDBE2025-6-PN	●	1.25	2.5	6	2	2.4	50	4	4	5.04	6.88	7.09	7.27	7.43	7.87	
EPDBE2025-10-PN	●			10						3.43	11.03	11.32	11.56	12.00	13.18	
EPDBE2025-15-PN	●			15						2.46	16.18	16.56	17.20	17.98	No interference	
EPDBE2025-20-PN	●			20						1.91	21.32	21.93	22.90	No interference	No interference	
EPDBE2025-25-PN	●			25						1.57	26.44	27.38	28.60	No interference	No interference	
EPDBE2025-30-PN	●			30						1.33	31.55	32.82	No interference	No interference	No interference	
EPDBE2030-8-PN	●	1.5	3	8	2.5	2.88	55	6	4	6.19	8.99	9.23	9.44	9.62	10.51	
EPDBE2030-10-PN	●			10						5.41	11.06	11.34	11.57	12.01	13.16	
EPDBE2030-13-PN	●			13						4.56	14.15	14.48	14.94	15.60	17.15	
EPDBE2030-16-PN	●			16						3.93	17.24	17.61	18.36	19.19	21.13	
EPDBE2030-20-PN	●			20						3.33	21.34	21.96	22.92	23.97	26.44	
EPDBE2030-25-PN	●			25						2.79	26.46	27.41	28.62	29.96	No interference	
EPDBE2030-30-PN	●	30	2.40	31.57	32.85	34.32	35.94	No interference								
EPDBE2030-35-PN	●	35	2.11	36.72	38.30	40.03	41.92	No interference								
EPDBE2035-15-PN	●	1.75	3.5	15	2.75	3.35	60	6	4	3.68	16.25	16.60	17.26	18.03	19.81	
EPDBE2035-25-PN	●			25						2.43	26.49	27.46	28.67	29.99	No interference	
EPDBE2035-35-PN	●			35						1.82	36.79	38.36	40.07	No interference	No interference	
EPDBE2035-45-PN	●			45						1.45	47.22	49.25	No interference	No interference	No interference	
EPDBE2040-10-PN	●			2						4	10	3	3.85	55	6	4
EPDBE2040-13-PN	●	13	3.57		14.19	14.50	14.95	15.59	17.08							
EPDBE2040-16-PN	●	16	3.01		17.27	17.63	18.37	19.18	No interference							
EPDBE2040-20-PN	●	20	2.49		21.37	21.99	22.93	23.96	No interference							
EPDBE2040-25-PN	●	25	2.05		26.49	27.44	28.63	29.95	No interference							
EPDBE2040-30-PN	●	30	1.74		31.59	32.89	34.34	No interference	No interference							
EPDBE2040-35-PN	●	35	1.51		36.78	38.33	40.04	No interference	No interference							
EPDBE2040-40-PN	●	40	1.34		41.99	43.78	No interference	No interference	No interference							
EPDBE2040-45-PN	●	45	1.20		47.20	49.23	No interference	No interference	No interference							
EPDBE2040-50-PN	●	50	1.08		52.42	54.68	No interference	No interference	No interference							
EPDBE2050-20-PN	●	2.5	5	20	3.5	4.85	65	6	4	1.42	21.36	21.95	No interference	No interference	No interference	
EPDBE2050-25-PN	●			25						1.14	26.48	27.39	No interference	No interference	No interference	
EPDBE2050-30-PN	●			30						0.95	31.58	No interference	No interference	No interference	No interference	
EPDBE2050-40-PN	●			40						0.72	41.97	No interference	No interference	No interference	No interference	
EPDBE2060-12-PN	●			12			0			No interference	No interference	No interference	No interference	No interference		
EPDBE2060-20-PN	●	3	6	20	6	5.85	65	6	-	0	No interference	No interference	No interference	No interference	No interference	
EPDBE2060-30-PN	●			30						0	No interference	No interference	No interference	No interference	No interference	
EPDBE2060-40-PN	●			40						0	No interference	No interference	No interference	No interference	No interference	
EPDBE2060-50-PN	●			50						0	No interference	No interference	No interference	No interference	No interference	

● : Stocked items.

2 Flutes

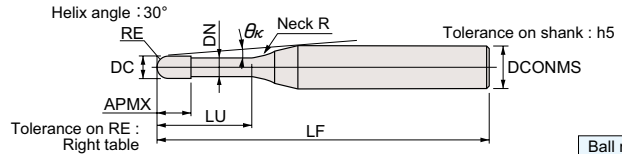

Ball radius RE	Tolerance on RE
RE ≤ 0.25	±0.003
0.25 < RE	±0.005

EPDBE2000-00.00-ATH

Item code	Stock	Size (mm)										The effective under-neck length for the various draft angles																
		Ball radius RE	Tool dia. DC	Under neck length LU	Flute length APMX	Neck dia. DN	Overall length LF	Shank dia. DCONMS	Neck R	Interference angle θ_k	0.5°	1°	1.5°	2°	3°													
																ATH												
EPDBE2001-0.2-ATH	●	0.05	0.1	0.2	0.08	0.08	45	4	1	11.76	0.35	0.37	0.39	0.41	0.44													
EPDBE2001-0.3-ATH	●			0.3																								
EPDBE2001-0.5-ATH	●			0.5																								
EPDBE2002-0.5-ATH	●	0.1	0.2	0.5	0.15	0.17	50	4	1	11.42	0.70	0.72	0.75	0.77	0.82													
EPDBE2002-0.75-ATH	●			0.75																								
EPDBE2002-1-ATH	●			1																								
EPDBE2002-1.25-ATH	●			1.25																								
EPDBE2002-1.5-ATH	●			1.5																								
EPDBE2002-2-ATH	●			2																								
EPDBE2002-2.5-ATH	●			2.5																								
EPDBE2002-3-ATH	●			3																								
EPDBE2003-0.5-ATH	●			0.15												0.3	0.5	0.25	0.27	50	4	2	11.47	0.78	0.82	0.86	0.90	0.98
EPDBE2003-0.75-ATH	●																0.75											
EPDBE2003-1-ATH	●	1																										
EPDBE2003-1.25-ATH	●	1.25																										
EPDBE2003-1.5-ATH	●	1.5																										
EPDBE2003-2-ATH	●	2																										
EPDBE2003-2.5-ATH	●	2.5																										
EPDBE2003-3-ATH	●	3																										
EPDBE2004-0.75-ATH	●	0.2	0.4	0.75	0.3	0.37	50	4	2	11.21	1.04	1.09	1.14	1.19	1.28													
EPDBE2004-1-ATH	●			1																								
EPDBE2004-1.5-ATH	●			1.5																								
EPDBE2004-2-ATH	●			2																								
EPDBE2004-2.5-ATH	●			2.5																								
EPDBE2004-3-ATH	●			3																								
EPDBE2004-3.5-ATH	●			3.5																								
EPDBE2004-4-ATH	●			4																								
EPDBE2004-4.5-ATH	●			4.5																								
EPDBE2005-1-ATH	●			0.25												0.5	1	0.35	0.47	50	4	2	10.94	1.31	1.37	1.42	1.47	1.57
EPDBE2005-1.5-ATH	●	1.5																										
EPDBE2005-2-ATH	●	2																										
EPDBE2005-2.5-ATH	●	2.5																										
EPDBE2005-3-ATH	●	3																										
EPDBE2005-4-ATH	●	4																										
EPDBE2005-5-ATH	●	5																										
EPDBE2005-5.5-ATH	●	5.5																										
EPDBE2005-6-ATH	●	6																										
EPDBE2005-8-ATH	●	8																										
EPDBE2006-1-ATH	●	0.3	0.6	1	0.4	0.57	50	4	4	10.98	1.44	1.54	1.63	1.71	1.88													
EPDBE2006-2-ATH	●			2																								
EPDBE2006-2.5-ATH	●			2.5																								
EPDBE2006-3-ATH	●			3																								
EPDBE2006-3.5-ATH	●			3.5																								
EPDBE2006-4-ATH	●			4																								
EPDBE2006-4.5-ATH	●			4.5																								
EPDBE2006-5-ATH	●			5																								
EPDBE2006-5.5-ATH	●			5.5																								
EPDBE2006-6-ATH	●			6																								
EPDBE2006-7-ATH	●			7																								
EPDBE2006-8-ATH	●			8																								
EPDBE2006-9-ATH	●			9																								
EPDBE2006-10-ATH	●			10																								
EPDBE2006-12-ATH	●	12																										

● : Stocked items.

Features
Dimensions
Ball PN Coating
Dimensions
Ball ATH Coating
Cutting condition
Ball High efficiency
Cutting condition
Ball High accuracy
Cutting condition
Ball High accuracy
Dimensions
Square PN Coating
Dimensions
Square ATH Coating
Cutting condition
Square High efficiency
Cutting condition
Square High accuracy
Technical Data

Line Up

Epoch Deep Ball Evolution

EPDBE-ATH

ATHCoating

2 Flutes

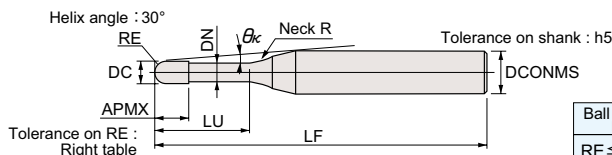

(mm)	
Ball radius RE	Tolerance on RE
RE ≤ 0.25	±0.003
0.25 < RE	±0.005

EPDBE2-ATH

Item code	Stock	Size (mm)										The effective under-neck length for the various draft angles				
		Ball radius RE	Tool dia. DC	Under neck length LU	Flute length APMX	Neck dia. DN	Overall length LF	Shank dia. DCONMS	Neck R	Interference angle θκ	0.5°	1°	1.5°	2°	3°	
																ATH
EPDBE2007-2-ATH	●	0.35	0.7	2	0.45	0.67	50	4	4	9.88	2.52	2.66	2.79	2.90	3.12	
EPDBE2007-4-ATH	●			4						8.18	4.64	4.86	5.04	5.20	5.48	
EPDBE2007-6-ATH	●			6						6.98	6.74	7.01	7.23	7.42	7.94	
EPDBE2007-8-ATH	●			8						6.09	8.83	9.14	9.39	9.61	10.60	
EPDBE2008-2-ATH	●	0.4	0.8	2	0.5	0.77	50	4	4	9.87	2.51	2.65	2.78	2.89	3.11	
EPDBE2008-4-ATH	●			4						8.14	4.64	4.85	5.03	5.19	5.47	
EPDBE2008-5-ATH	●			5						7.48	5.69	5.93	6.13	6.31	6.61	
EPDBE2008-6-ATH	●			6						6.92	6.74	7.01	7.23	7.41	7.92	
EPDBE2008-8-ATH	●			8						6.01	8.83	9.14	9.39	9.60	10.58	
EPDBE2008-10-ATH	●			10						5.32	10.91	11.26	11.53	11.97	13.23	
EPDBE2009-2-ATH	●	0.45	0.9	2	0.6	0.87	50	4	4	9.87	2.51	2.65	2.77	2.89	3.10	
EPDBE2009-4-ATH	●			4						8.09	4.64	4.85	5.03	5.18	5.46	
EPDBE2009-6-ATH	●			6						6.85	6.74	7.00	7.22	7.41	7.91	
EPDBE2009-8-ATH	●			8						5.94	8.83	9.14	9.38	9.60	10.56	
EPDBE2010-2-ATH	●	0.5	1	2	0.8	0.96	50	4	4	9.84	2.54	2.67	2.79	2.90	3.11	
EPDBE2010-3-ATH	●			3						8.84	3.61	3.78	3.93	4.06	4.30	
EPDBE2010-4-ATH	●			4						8.02	4.66	4.87	5.04	5.20	5.47	
EPDBE2010-5-ATH	●			5						7.34	5.72	5.95	6.14	6.31	6.61	
EPDBE2010-6-ATH	●			6						6.77	6.76	7.02	7.23	7.42	7.92	
EPDBE2010-7-ATH	●			7						6.28	7.81	8.09	8.32	8.52	9.25	
EPDBE2010-8-ATH	●			8			5.85	8.85	9.15	9.40	9.61	10.58				
EPDBE2010-9-ATH	●			9			5.48	9.89	10.21	10.47	10.78	11.91				
EPDBE2010-10-ATH	●			10			5.15	10.93	11.27	11.54	11.98	13.23				
EPDBE2010-12-ATH	●			12			4.60	13.00	13.37	13.72	14.37	15.89				
EPDBE2010-13-ATH	●	13	4.37	14.04	14.42	14.86	15.57	17.21								
EPDBE2010-14-ATH	●								14	4.16	15.07	15.47	16.00	16.76	18.54	
EPDBE2010-16-ATH	●	16	3.79	17.13	17.56	18.28	19.16	21.20								
EPDBE2010-18-ATH	●	18	3.49	19.19	19.66	20.56	21.55	23.85								
EPDBE2010-20-ATH	●	20	3.23	21.25	21.84	22.84	23.94	26.51								
EPDBE2011-2-ATH	●	0.55	1.1	2	1	1.05	50	4	4	9.81	2.58	2.70	2.81	2.92	3.12	
EPDBE2011-4-ATH	●			4						7.95	4.69	4.89	5.06	5.21	5.48	
EPDBE2011-6-ATH	●			6						6.68	6.79	7.04	7.25	7.43	7.94	
EPDBE2011-8-ATH	●			8						5.76	8.87	9.17	9.41	9.61	10.59	
EPDBE2011-10-ATH	●	10	5.06	10.95	11.28	11.55	12.00	13.25								
EPDBE2012-4-ATH	●	0.6	1.2	4	1.1	1.15	50	4	4	7.89	4.69	4.88	5.05	5.20	5.47	
EPDBE2012-6-ATH	●			6						6.60	6.79	7.03	7.24	7.42	7.92	
EPDBE2012-8-ATH	●			8						5.67	8.87	9.16	9.40	9.61	10.58	
EPDBE2012-10-ATH	●			10						4.97	10.95	11.28	11.54	11.99	13.23	
EPDBE2012-12-ATH	●	12	4.43	13.02	13.38	13.73	14.38	15.89								
EPDBE2014-8-ATH	●	0.7	1.4	8	1.3	1.34	50	4	4	5.48	8.89	9.18	9.41	9.61	10.58	
EPDBE2014-12-ATH	●			12			4.24			13.04	13.39	13.74	14.39	15.89		
EPDBE2014-16-ATH	●			16			3.46			17.16	17.57	18.31	19.17	21.20		
EPDBE2015-4-ATH	●	0.75	1.5	4	1.35	1.44	50	4	4	7.68	4.71	4.89	5.06	5.20	5.46	
EPDBE2015-6-ATH	●			6						6.33	6.81	7.04	7.25	7.42	7.91	
EPDBE2015-8-ATH	●			8						5.39	8.89	9.17	9.41	9.61	10.56	
EPDBE2015-10-ATH	●			10						4.68	10.96	11.29	11.55	11.98	13.22	
EPDBE2015-12-ATH	●			12			4.14			13.03	13.39	13.74	14.38	15.87		
EPDBE2015-14-ATH	●			14			3.72			15.10	15.48	16.02	16.77	18.52		
EPDBE2015-16-ATH	●														16	3.77
EPDBE2015-18-ATH	●			18			3.08			19.22	19.69	20.58	21.56	23.83		
EPDBE2015-20-ATH	●	20	2.84	21.27	21.87	22.86	23.95	No interference								
EPDBE2016-8-ATH	●	0.8	1.6	8	1.4	1.54	50	4	4	5.28	8.89	9.17	9.40	9.60	10.55	
EPDBE2016-12-ATH	●			12			4.05			13.03	13.39	13.73	14.37	15.85		
EPDBE2016-16-ATH	●			16			3.28			17.16	17.57	18.29	19.15	21.16		
EPDBE2016-20-ATH	●			20			2.75			21.27	21.87	22.86	23.94	No interference		

● : Stocked items.

Detailed shape below neck

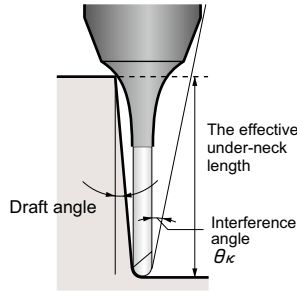
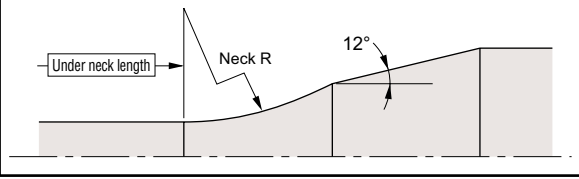

[Note]

The effective under-neck length is different from Epoch Deep Ball EPDB. Please recheck the interference region.

EPDBE2000-ATH

Item code	Stock ATH	Size (mm)									The effective under-neck length for the various draft angles				
		Ball radius	Tool dia.	Under neck length	Flute length	Neck dia.	Overall length	Shank dia.	Neck R	Interference angle	0.5°	1°	1.5°	2°	3°
		RE	DC	LU	APMX	DN	LF	DCONMS	R	θκ					
EPDBE2018-8-ATH	●	0.9	1.8	8	1.6	1.73	50	4	4	5.06	8.91	9.18	9.41	9.61	10.54
EPDBE2018-12-ATH	●			12			55			3.83	13.05	13.40	13.74	14.38	15.85
EPDBE2018-16-ATH	●			16			60			3.09	17.17	17.58	18.31	19.16	21.16
EPDBE2018-20-ATH	●			20			2.58			21.28	21.88	22.87	23.95	No interference	
EPDBE2020-3-ATH	●	1	2	3	1.7	1.92	50	4	4	8.26	3.71	3.84	3.96	4.07	4.29
EPDBE2020-4-ATH	●			4						7.23	4.75	4.92	5.07	5.21	5.45
EPDBE2020-6-ATH	●			6						5.78	6.84	7.07	7.26	7.43	7.89
EPDBE2020-8-ATH	●			8						4.81	8.92	9.19	9.42	9.61	10.54
EPDBE2020-10-ATH	●			10			4.12			11.00	11.30	11.56	11.99	13.20	
EPDBE2020-12-ATH	●			12			3.61			13.06	13.41	13.76	14.39	15.85	
EPDBE2020-13-ATH	●			13			3.39			14.10	14.45	14.90	15.58	17.18	
EPDBE2020-14-ATH	●			14			3.20			15.13	15.50	16.04	16.78	18.51	
EPDBE2020-16-ATH	●			16			2.88			17.19	17.59	18.32	19.17	No interference	
EPDBE2020-18-ATH	●			18			2.62			19.24	19.72	20.60	21.57	No interference	
EPDBE2020-20-ATH	●			20			2.40			21.30	21.90	22.88	23.96	No interference	
EPDBE2020-22-ATH	●			22			2.22			23.35	24.08	25.16	26.35	No interference	
EPDBE2020-25-ATH	●			25			1.99			26.42	27.35	28.58	No interference	No interference	
EPDBE2020-30-ATH	●			30			1.70			31.53	32.80	34.29	No interference	No interference	
EPDBE2020-35-ATH	●			35			1.48			36.65	38.24	No interference	No interference	No interference	
EPDBE2020-40-ATH	●			40			1.31			41.86	43.69	No interference	No interference	No interference	
EPDBE2025-6-ATH	●	1.25	2.5	6	2	2.4	50	4	4	5.04	6.88	7.09	7.27	7.43	7.87
EPDBE2025-10-ATH	●			10						3.43	11.03	11.32	11.56	12.00	13.18
EPDBE2025-15-ATH	●			15						2.46	16.18	16.56	17.20	17.98	No interference
EPDBE2025-20-ATH	●			20						1.91	21.32	21.93	22.90	No interference	No interference
EPDBE2025-25-ATH	●			25			1.57			26.44	27.38	28.60	No interference	No interference	
EPDBE2025-30-ATH	●	30	1.33	31.55	32.82	No interference	No interference	No interference							
EPDBE2030-8-ATH	●	1.5	3	8	2.5	2.88	55	6	4	6.19	8.99	9.23	9.44	9.62	10.51
EPDBE2030-10-ATH	●			10						5.41	11.06	11.34	11.57	12.01	13.16
EPDBE2030-13-ATH	●			13						4.56	14.15	14.48	14.94	15.60	17.15
EPDBE2030-16-ATH	●			16			3.93			17.24	17.61	18.36	19.19	21.13	
EPDBE2030-20-ATH	●			20			3.33			21.34	21.96	22.92	23.97	26.44	
EPDBE2030-25-ATH	●			25			2.79			26.46	27.41	28.62	29.96	No interference	
EPDBE2030-30-ATH	●	30	2.40	31.57	32.85	34.32	35.94	No interference							
EPDBE2030-35-ATH	●	35	2.11	36.72	38.30	40.03	41.92	No interference							
EPDBE2035-15-ATH	●	1.75	3.5	15	2.75	3.35	60	6	4	3.68	16.25	16.60	17.26	18.03	19.81
EPDBE2035-25-ATH	●			25			2.43			26.49	27.46	28.67	29.99	No interference	
EPDBE2035-35-ATH	●			35			1.82			36.79	38.36	40.07	No interference	No interference	
EPDBE2035-45-ATH	●			45			1.45			47.22	49.25	No interference	No interference	No interference	
EPDBE2040-10-ATH	●	2	4	10	3	3.85	55	6	4	4.38	11.10	11.36	11.58	12.00	13.10
EPDBE2040-13-ATH	●			13			3.57			14.19	14.50	14.95	15.59	17.08	
EPDBE2040-16-ATH	●			16			3.01			17.27	17.63	18.37	19.18	No interference	
EPDBE2040-20-ATH	●			20			2.49			21.37	21.99	22.93	23.96	No interference	
EPDBE2040-25-ATH	●			25			2.05			26.49	27.44	28.63	29.95	No interference	
EPDBE2040-30-ATH	●			30			1.74			31.59	32.89	34.34	No interference	No interference	
EPDBE2040-35-ATH	●			35			1.51			36.78	38.33	40.04	No interference	No interference	
EPDBE2040-40-ATH	●			40			1.34			41.99	43.78	No interference	No interference	No interference	
EPDBE2040-45-ATH	●			45			1.20			47.20	49.23	No interference	No interference	No interference	
EPDBE2040-50-ATH	●			50			1.08			52.42	54.68	No interference	No interference	No interference	
EPDBE2050-20-ATH	●	2.5	5	20	3.5	4.85	65	6	4	1.42	21.36	21.95	No interference	No interference	No interference
EPDBE2050-25-ATH	●			25			1.14			26.48	27.39	No interference	No interference	No interference	
EPDBE2050-30-ATH	●			30			0.95			31.58	No interference	No interference	No interference	No interference	
EPDBE2050-40-ATH	●			40			0.72			41.97	No interference	No interference	No interference	No interference	
EPDBE2060-12-ATH	●	3	6	12	6	5.85	60	6	-	0	No interference	No interference	No interference	No interference	No interference
EPDBE2060-20-ATH	●			20			0			No interference	No interference	No interference	No interference	No interference	
EPDBE2060-30-ATH	●			30			0			No interference	No interference	No interference	No interference	No interference	
EPDBE2060-50-ATH	●			50			0			No interference	No interference	No interference	No interference	No interference	

● : Stocked items.

Features

Dimensions
Ball/PN Coating

Dimensions
Ball/ATH Coating

Cutting condition
Ball/High efficiency

Cutting condition
Ball/High accuracy

Dimensions
Square/PN Coating

Dimensions
Square/ATH Coating

Cutting condition
Square/High efficiency

Cutting condition
Square/High accuracy

Technical Data

Recommended Cutting Conditions

High efficiency cutting condition

High accuracy cutting condition

Please refer to P.13 about high accuracy cutting conditions

Epoch Deep Ball Evolution **EPDBE-PN** **EPDBE-ATH**

Recommended range				PN series											
				ATH series											
Work material				1		2		3		4		5		6	
				Coppers		Carbon steels, Alloy steels (180~250HB)		Stainless steels, Tool steels (25~35HRC)		Pre-hardened steels (35~45HRC)		Hardened steels (45~55HRC)		Hardened steels (55~65HRC)	
Ratio to standard depth of cut				120%		100%		90%		80%		65%		60%	
Ball radius RE (mm)	Tool dia. DC (mm)	Under neck length LU (mm)	a_p (mm)	Revolution n (min ⁻¹)	Feed rate v_f (mm/min)	Revolution n (min ⁻¹)	Feed rate v_f (mm/min)	Revolution n (min ⁻¹)	Feed rate v_f (mm/min)	Revolution n (min ⁻¹)	Feed rate v_f (mm/min)	Revolution n (min ⁻¹)	Feed rate v_f (mm/min)	Revolution n (min ⁻¹)	Feed rate v_f (mm/min)
0.05	0.1	0.2	0.008	50,000	300	50,000	250	50,000	250	50,000	225	50,000	200	50,000	188
		0.3	0.006	50,000	300	50,000	250	50,000	250	50,000	225	50,000	200	50,000	188
		0.5	0.004	50,000	300	50,000	250	50,000	250	50,000	225	50,000	200	50,000	188
0.1	0.2	0.5	0.02	50,000	420	50,000	350	50,000	350	50,000	325	45,500	273	42,000	210
		0.75	0.017	50,000	420	50,000	350	50,000	350	50,000	325	45,500	273	42,000	210
		1	0.014	50,000	420	50,000	350	50,000	350	50,000	325	45,500	273	42,000	210
		1.25	0.011	50,000	378	50,000	315	48,600	306	45,900	269	40,500	219	37,800	170
		1.5	0.008	50,000	378	50,000	315	48,600	306	45,900	269	40,500	219	37,800	170
		2	0.008	50,000	378	50,000	315	48,600	306	45,900	269	40,500	219	37,800	170
		2.5	0.006	48,000	323	48,000	269	43,200	242	40,800	212	36,000	173	33,600	134
		3	0.004	48,000	323	48,000	269	43,200	242	40,800	212	36,000	173	33,600	134
0.15	0.3	0.5	0.027	50,000	600	50,000	500	50,000	500	50,000	450	45,000	383	42,000	336
		0.75	0.024	50,000	600	50,000	500	50,000	500	50,000	450	45,000	383	42,000	336
		1	0.021	50,000	600	50,000	500	50,000	500	50,000	450	45,000	383	42,000	336
		1.25	0.019	50,000	600	50,000	500	50,000	500	50,000	450	45,000	383	42,000	336
		1.5	0.016	50,000	600	50,000	500	50,000	500	50,000	450	45,000	383	42,000	336
		2	0.012	50,000	540	50,000	450	48,600	437	45,900	372	40,500	310	37,800	272
		2.5	0.01	50,000	540	50,000	450	48,600	437	45,900	372	40,500	310	37,800	272
0.2	0.4	3	0.008	50,000	540	50,000	450	48,600	437	45,900	372	40,500	310	37,800	272
		0.75	0.043	50,000	967	50,000	840	50,000	839	50,000	770	46,800	655	43,680	612
		1	0.04	50,000	967	50,000	840	50,000	839	50,000	770	46,800	655	43,680	612
		1.5	0.034	50,000	829	50,000	720	50,000	719	50,000	660	46,800	468	43,680	437
		2	0.028	50,000	691	50,000	600	50,000	600	50,000	550	46,800	468	43,680	437
		2.5	0.022	50,000	560	43,200	467	38,880	420	36,720	364	32,400	292	36,288	272
		3	0.016	50,000	560	43,200	467	38,880	420	36,720	364	32,400	292	36,288	272
		3.5	0.012	50,000	560	43,200	467	38,880	420	36,720	364	32,400	292	36,288	272
0.25	0.5	4	0.01	50,000	560	43,200	467	38,880	420	36,720	364	32,400	292	36,288	272
		4.5	0.008	46,080	470	38,400	392	34,560	353	32,640	305	28,800	245	26,880	228
		1	0.045	50,000	1,500	50,000	1,500	46,800	1,404	44,200	1,193	39,000	1,053	36,400	743
		1.5	0.04	50,000	1,500	50,000	1,500	46,800	1,404	44,200	1,193	39,000	1,053	36,400	681
		2	0.035	50,000	1,200	50,000	1,200	46,800	1,123	44,200	955	39,000	842	36,400	681
		2.5	0.033	50,000	1,081	50,000	1,000	42,120	758	39,780	645	35,100	568	32,760	502
		3	0.03	50,000	900	46,800	842	42,120	758	39,780	645	35,100	568	25,200	386
		4	0.02	43,200	778	36,000	648	32,400	583	30,600	496	32,400	524	25,200	386
0.3	0.6	5	0.018	43,200	778	36,000	648	32,400	583	30,600	496	32,400	524	25,200	386
		5.5	0.015	38,400	653	32,000	544	28,800	490	27,200	416	24,000	367	22,400	324
		6	0.013	38,400	653	32,000	544	28,800	490	27,200	416	24,000	367	22,400	324
		8	0.008	38,400	653	32,000	544	28,800	490	27,200	416	24,000	367	22,400	324
		1	0.075	50,000	2,250	50,000	2,250	50,000	2,250	50,000	1,950	48,000	1,728	44,800	1,344
		2	0.063	50,000	2,250	50,000	2,250	50,000	2,250	50,000	1,950	48,000	1,728	44,800	1,344
		2.5	0.046	50,000	1,800	50,000	1,800	50,000	1,800	50,000	1,560	48,000	1,382	44,800	986
		3	0.041	50,000	1,800	50,000	1,800	50,000	1,800	50,000	1,560	48,000	1,382	44,800	986
		3.5	0.035	50,000	1,710	50,000	1,710	50,000	1,709	48,960	1,452	43,200	1,183	40,320	843
		4	0.026	50,000	1,710	50,000	1,710	50,000	1,709	48,960	1,452	43,200	1,183	40,320	766
0.35	0.7	4.5	0.022	50,000	1,350	50,000	1,350	48,600	1,313	45,900	1,074	40,500	875	37,800	681
		5	0.02	50,000	1,350	46,800	1,264	42,120	1,138	39,780	931	35,100	758	32,760	590
		5.5	0.017	50,000	1,350	46,800	1,264	42,120	1,138	39,780	931	35,100	758	32,760	590
		6	0.015	50,000	1,350	46,800	1,264	42,120	1,138	39,780	931	35,100	758	32,760	590
		7	0.015	38,400	979	32,000	816	28,800	881	27,200	601	24,000	490	22,400	495
		8	0.015	38,400	979	32,000	816	28,800	734	27,200	601	24,000	490	22,400	381
		9	0.012	38,400	979	32,000	816	28,800	734	27,200	601	24,000	490	22,400	381
		10	0.009	33,600	857	28,000	714	25,200	643	23,800	526	21,000	428	19,600	333
		12	0.007	28,800	691	24,000	576	21,600	518	20,400	424	18,000	346	16,800	269
		2	0.092	50,000	2,475	50,000	2,475	50,000	2,475	50,000	2,155	48,000	1,932	42,000	1,188
4	0.041	50,000	1,880	50,000	1,880	50,000	1,880	48,960	1,603	43,200	1,321	37,800	846		
6	0.027	50,000	1,485	46,800	1,390	42,120	1,251	39,780	1,028	35,100	848	30,240	641		
8	0.02	38,400	1,013	32,000	844	28,800	760	27,200	625	24,000	515	22,400	422		

[Note] Please refer to P.12

Recommended range				PN series											
				ATH series											
Work material				1		2		3		4		5		6	
				Coppers		Carbon steels, Alloy steels (180~250HB)		Stainless steels, Tool steels (25~35HRC)		Pre-hardened steels (35~45HRC)		Hardened steels (45~55HRC)		Hardened steels (55~65HRC)	
Ratio to standard depth of cut				120%		100%		90%		80%		65%		60%	
Ball radius RE (mm)	Tool dia. DC (mm)	Under neck length LU (mm)	ap (mm)	Revolution n min ⁻¹	Feed rate vf mm/min	Revolution n min ⁻¹	Feed rate vf mm/min	Revolution n min ⁻¹	Feed rate vf mm/min	Revolution n min ⁻¹	Feed rate vf mm/min	Revolution n min ⁻¹	Feed rate vf mm/min	Revolution n min ⁻¹	Feed rate vf mm/min
0.4	0.8	2	0.12	50,000	2,700	50,000	2,700	50,000	2,700	50,000	2,400	48,000	2,592	44,800	1,882
		4	0.078	50,000	2,700	50,000	2,700	50,000	2,700	50,000	2,400	48,000	2,592	44,800	1,882
		5	0.059	50,000	2,431	50,000	2,429	50,000	2,431	48,960	2,114	43,200	2,123	40,320	1,524
		6	0.042	50,000	2,269	50,000	2,267	45,360	2,058	42,840	1,727	37,800	1,429	35,280	1,245
		8	0.02	49,920	1,617	41,600	1,348	37,440	1,213	35,360	1,018	31,200	842	29,120	733
0.45	0.9	2	0.135	50,000	3,197	50,000	3,197	50,000	3,197	50,000	2,821	45,600	2,411	42,560	2,138
		4	0.081	50,000	2,771	50,000	2,771	50,000	2,771	48,450	2,369	42,750	1,959	39,900	1,737
		6	0.05	50,000	2,302	47,880	2,020	43,092	1,818	40,698	1,515	35,910	1,253	33,516	1,111
		8	0.036	43,776	1,679	36,480	1,399	32,832	1,259	31,008	1,049	27,360	868	25,536	770
0.5	1	2	0.2	50,000	3,750	50,000	3,750	48,600	3,645	45,900	3,098	43,200	2,722	37,800	2,268
		3	0.2	50,000	3,750	50,000	3,750	48,600	3,645	45,900	3,098	43,200	2,722	37,800	2,268
		4	0.14	50,000	3,750	50,000	3,750	48,600	3,645	45,900	3,098	43,200	2,722	37,800	2,268
		5	0.09	50,000	3,500	46,800	3,276	42,120	2,948	39,780	2,596	43,200	2,540	32,760	1,835
		6	0.06	50,000	3,151	42,120	2,654	40,824	2,558	38,556	2,319	38,880	2,353	29,484	1,379
		7	0.06	46,656	2,100	38,880	1,750	34,992	1,574	33,048	1,338	31,590	1,323	27,216	1,061
		8	0.06	46,656	2,100	38,880	1,750	34,992	1,574	33,048	1,338	31,590	1,323	27,216	979
		9	0.045	46,656	2,100	38,880	1,750	34,992	1,574	33,048	1,338	31,590	1,323	27,216	979
		10	0.038	46,656	2,100	38,880	1,750	34,992	1,574	33,048	1,338	31,590	1,323	27,216	979
		12	0.025	34,560	1,469	28,800	1,224	25,920	1,102	24,480	936	21,600	771	20,160	685
		13	0.023	34,560	1,469	28,800	1,224	25,920	1,102	24,480	936	21,600	771	20,160	685
		14	0.02	34,560	1,469	28,800	1,224	25,920	1,102	24,480	936	21,600	771	20,160	685
		16	0.015	34,560	1,469	28,800	1,224	25,920	1,102	24,480	936	21,600	771	20,160	685
18	0.012	30,240	1,210	25,200	1,008	22,680	907	21,420	771	18,900	635	17,640	564		
20	0.01	25,920	1,037	21,600	864	19,440	778	18,360	661	16,200	544	15,120	484		
0.55	1.1	2	0.2	50,000	3,924	50,000	3,924	45,360	3,560	42,840	2,927	37,800	2,452	35,280	2,176
		4	0.14	50,000	3,924	50,000	3,924	45,360	3,560	42,840	2,927	37,800	2,452	35,280	2,176
		6	0.06	47,736	2,767	39,780	2,306	35,802	2,075	33,813	1,706	29,835	1,430	27,846	1,268
		8	0.06	47,736	2,306	39,780	2,306	35,802	1,729	31,212	1,312	27,540	1,100	25,704	975
		10	0.038	47,736	2,306	39,780	1,774	35,802	1,729	31,212	1,312	27,540	1,100	25,704	975
0.6	1.2	4	0.16	50,000	3,924	46,154	3,743	41,538	3,260	39,230	2,717	36,923	2,555	32,307	1,860
		6	0.11	44,928	2,570	37,440	2,142	33,696	2,103	31,824	2,069	30,240	2,062	26,208	1,048
		8	0.06	44,928	2,570	37,440	2,142	33,696	2,103	31,824	2,069	30,240	2,062	26,208	1,048
		10	0.053	41,472	1,940	34,560	1,708	31,104	1,456	29,376	1,322	27,000	1,069	24,192	871
		12	0.045	41,472	1,940	34,560	1,618	31,104	1,456	29,376	1,322	25,920	1,026	24,192	871
0.7	1.4	8	0.11	39,312	2,830	32,760	2,359	29,484	2,123	27,846	1,805	24,570	1,533	22,932	1,376
		12	0.053	36,288	1,960	30,240	1,633	27,216	1,470	25,704	1,249	22,680	1,062	21,168	953
		16	0.035	26,880	1,371	22,400	1,142	20,160	1,028	19,040	874	16,800	743	15,680	666
0.75	1.5	4	0.2	50,000	4,951	42,000	4,158	37,800	3,742	35,700	3,213	31,500	2,552	29,400	2,205
		6	0.2	50,000	4,951	42,000	4,158	37,800	3,742	35,700	3,213	31,500	2,552	29,400	2,205
		8	0.09	39,312	2,802	32,760	2,627	29,484	2,101	27,846	1,805	24,570	1,434	22,932	1,239
		10	0.09	36,288	2,586	30,240	2,156	27,216	1,940	25,704	1,666	22,680	1,323	21,168	1,143
		12	0.09	36,288	2,155	30,240	1,796	27,216	1,616	25,704	1,388	22,680	1,103	21,168	953
		14	0.075	32,256	1,810	30,240	1,796	24,192	1,357	22,848	1,165	20,160	925	18,816	799
		16	0.038	26,880	1,508	22,400	1,257	20,160	1,131	19,040	971	16,800	771	15,680	666
		18	0.038	26,880	1,508	22,400	1,257	20,160	1,131	19,040	971	16,800	771	15,680	666
0.8	1.6	8	0.22	43,680	3,669	36,400	3,058	32,760	2,752	30,940	2,493	27,300	2,129	23,660	1,590
		12	0.098	39,312	3,467	32,760	2,889	29,484	2,601	27,846	2,176	24,570	1,858	21,294	1,289
		16	0.06	33,696	2,123	28,080	1,769	25,272	1,592	23,868	1,332	21,060	1,138	19,656	991
		20	0.04	24,960	1,485	20,800	1,238	18,720	1,114	17,680	932	15,600	796	14,560	693
		8	0.26	40,560	3,894	33,800	3,245	30,420	2,920	28,730	2,413	25,350	2,008	23,660	1,704
0.9	1.8	12	0.105	33,696	2,426	28,080	2,022	25,272	1,819	23,868	1,504	21,060	1,250	19,656	1,062
		16	0.068	33,696	2,426	28,080	2,022	25,272	1,819	23,868	1,504	21,060	1,250	19,656	1,062
		20	0.045	24,960	1,697	20,800	1,414	18,720	1,273	17,680	1,052	15,600	875	14,560	743
		3	0.4	37,800	5,670	31,500	4,725	28,350	4,253	26,775	3,616	23,625	3,049	22,050	2,646
1	2	4	0.4	37,800	5,670	31,500	4,725	28,350	4,253	26,775	3,616	23,625	3,049	22,050	2,646
		6	0.4	37,800	5,103	31,500	4,253	28,350	3,827	26,775	3,213	23,625	2,693	22,050	2,381
		8	0.28	37,800	5,103	31,500	4,253	28,350	3,827	26,775	3,213	23,625	2,693	22,050	2,381
		10	0.21	35,280	4,234	29,400	3,528	26,460	3,175	24,990	2,699	22,050	2,249	19,110	1,468

[Note] Please refer to P.12

Features
Dimensions
Ball/PN Coating
Dimensions
Ball/ATH Coating
Cutting condition
Ball/High efficiency
Cutting condition
Ball/High accuracy
Cutting condition
Ball/High accuracy
Dimensions
Square/PN Coating
Dimensions
Square/ATH Coating
Cutting condition
Square/High efficiency
Cutting condition
Square/High accuracy
Technical Data

Recommended Cutting Conditions

High efficiency cutting condition

High accuracy cutting condition

Please refer to P.13 about high accuracy cutting conditions

Epoch Deep Ball Evolution **EPDBE-PN** **EPDBE-ATH**

Recommended range				PN series											
				ATH series											
Work material				1		2		3		4		5		6	
				Coppers		Carbon steels, Alloy steels (180~250HB)		Stainless steels, Tool steels (25~35HRC)		Pre-hardened steels (35~45HRC)		Hardened steels (45~55HRC)		Hardened steels (55~65HRC)	
Ratio to standard depth of cut				120%		100%		90%		80%		65%		60%	
Ball radius RE (mm)	Tool dia. DC (mm)	Under neck length LU (mm)	a_p (mm)	Revolution n min ⁻¹	Feed rate v_f mm/min	Revolution n min ⁻¹	Feed rate v_f mm/min	Revolution n min ⁻¹	Feed rate v_f mm/min	Revolution n min ⁻¹	Feed rate v_f mm/min	Revolution n min ⁻¹	Feed rate v_f mm/min	Revolution n min ⁻¹	Feed rate v_f mm/min
1	2	12	0.12	31,752	3,809	26,460	3,175	23,814	2,858	22,491	2,430	19,845	2,051	17,199	1,321
		13	0.12	31,752	3,809	26,460	3,175	23,814	2,858	22,491	2,430	19,845	2,024	15,876	1,016
		14	0.12	31,752	3,301	26,460	2,752	23,814	2,477	22,491	2,106	18,428	1,629	15,876	1,016
		16	0.12	29,484	2,123	24,570	1,769	22,113	1,593	20,885	1,353	18,428	1,467	15,876	914
		18	0.09	27,216	1,960	22,680	1,633	20,412	1,470	19,278	1,249	18,428	1,354	15,876	914
		20	0.075	27,216	1,960	22,680	1,633	20,412	1,470	19,278	1,249	18,428	1,128	15,876	914
		22	0.05	21,420	1,457	17,850	1,214	16,065	1,092	15,173	929	13,388	774	14,994	816
		25	0.05	20,160	1,371	16,800	1,142	15,120	1,028	14,280	874	12,600	728	14,112	768
		30	0.03	20,160	1,371	16,800	1,142	15,120	1,028	14,280	874	12,600	728	14,112	768
		35	0.025	17,640	1,129	14,700	941	13,230	847	12,495	720	11,025	600	10,290	527
40	0.022	15,120	968	12,600	806	11,340	726	10,710	617	9,450	514	8,820	452		
1.25	2.5	6	0.5	33,300	6,075	27,750	5,063	24,975	4,556	23,588	3,797	20,813	3,088	19,425	2,531
		10	0.34	33,300	6,075	27,750	5,063	24,975	4,556	23,588	3,797	20,813	3,088	19,425	2,531
		15	0.15	25,974	3,411	21,645	2,842	19,481	2,558	18,398	2,132	16,234	2,023	15,152	1,421
		20	0.12	23,976	2,624	19,980	2,186	17,982	1,968	16,983	1,640	16,234	1,445	13,986	1,093
		25	0.098	23,976	2,360	19,980	1,967	17,982	1,770	16,983	1,475	14,985	1,200	13,986	983
30	0.055	17,760	1,836	14,800	1,530	13,320	1,377	12,580	1,148	11,100	933	10,360	765		
1.5	3	8	0.6	28,800	6,480	24,000	5,400	21,600	4,860	20,400	4,100	18,000	3,402	16,800	3,024
		10	0.42	28,800	6,480	24,000	5,400	21,600	4,860	20,400	4,100	18,000	3,402	16,800	3,024
		13	0.315	26,880	4,838	22,400	4,032	20,160	3,629	19,040	3,061	16,800	2,540	15,680	2,258
		16	0.315	26,880	4,355	22,400	3,629	20,160	3,266	19,040	2,755	16,800	2,286	14,560	1,888
		20	0.18	22,464	3,033	18,720	2,527	16,848	2,275	15,912	1,919	14,040	1,593	12,096	1,307
		25	0.12	22,464	3,033	18,720	2,527	16,848	2,275	15,912	1,919	14,040	1,593	12,096	1,307
		30	0.12	20,736	2,800	17,280	2,333	15,552	2,100	14,688	1,771	12,960	1,470	12,096	1,307
35	0.08	15,360	1,958	12,800	1,632	11,520	1,469	10,880	1,239	9,600	1,028	10,752	1,097		
1.75	3.5	15	0.36	21,450	4,399	17,875	3,666	16,088	3,299	15,194	2,750	13,406	2,236	12,513	1,833
		25	0.21	17,820	2,736	14,850	2,280	13,365	2,052	12,623	1,710	11,138	1,391	10,395	1,140
		35	0.09	17,820	2,736	14,850	2,280	13,365	2,052	12,623	1,710	11,138	1,391	10,395	1,140
		45	0.09	13,200	1,918	11,000	1,598	9,900	1,438	9,350	1,199	8,250	975	7,700	799
2	4	10	0.6	20,700	6,210	17,250	5,175	15,525	4,658	14,663	3,960	12,938	3,299	12,075	2,898
		13	0.48	20,700	6,210	17,250	5,175	15,525	4,658	14,663	3,960	12,938	3,299	12,075	2,898
		16	0.42	20,700	6,210	17,250	5,175	15,525	4,658	14,663	3,960	12,938	3,299	12,075	2,898
		20	0.42	17,940	4,306	14,950	3,588	13,455	3,229	12,708	2,746	11,213	2,287	10,465	2,009
		25	0.24	16,146	3,488	13,455	2,906	12,110	2,616	11,437	2,223	10,092	2,162	9,419	1,627
		30	0.16	14,904	2,683	12,420	2,236	11,178	2,012	10,558	1,710	9,316	1,426	8,694	1,252
		35	0.1	14,904	2,683	12,420	2,236	11,178	2,012	10,558	1,710	9,316	1,426	8,694	1,252
		40	0.1	14,904	2,683	12,420	2,236	11,178	2,012	10,558	1,710	9,316	1,426	8,694	1,252
		45	0.1	11,040	1,877	9,200	1,564	8,280	1,408	7,820	1,196	6,900	997	6,440	876
50	0.1	11,040	1,877	9,200	1,564	8,280	1,408	7,820	1,196	6,900	997	6,440	876		
2.5	5	20	0.525	15,120	5,443	12,600	4,536	11,340	4,082	10,710	3,213	9,450	2,835	8,820	2,381
		25	0.525	14,040	5,054	11,700	3,650	10,530	3,791	9,945	2,984	8,775	2,633	8,190	2,211
		30	0.3	12,636	4,549	10,530	2,780	9,477	3,413	8,951	2,685	7,898	2,369	7,371	1,991
		40	0.2	11,664	2,520	9,720	2,100	8,748	1,890	8,262	1,487	7,290	1,313	6,804	1,103
3	6	12	0.6	16,200	6,804	13,500	5,670	12,150	5,103	11,475	4,253	10,125	3,459	9,450	2,835
		20	0.5	15,300	5,967	12,750	4,973	11,475	4,475	10,838	3,729	9,563	3,033	8,925	2,486
		30	0.42	12,480	3,594	10,400	2,995	9,360	2,696	8,840	2,122	7,800	2,028	7,280	1,572
		50	0.15	10,368	2,687	8,640	2,239	7,776	2,016	7,344	1,587	6,480	1,400	6,048	1,175

- ※(1) a_p is shown as the criteria for Group 2 workpieces. For other groups, adjust the cutting depth according to the cutting depth factors in the above table.
- ※(2) When performing cutting where cutting chips may cause clogging, such as for rib processing, blind grooves, etc., cutting depth setting should be set by multiplying a cutting depth factor to calculate the cutting depth amount, and this amount should then be reduced to 80% of the calculated value.
- ※(3) Adjust by setting a_e to $(3 \text{ to } 5) \times (a_p) \times (\text{cutting depth ratio})$. When performing finishing processing, calculate the theoretical cusp height and set accordingly.

Cutting depth setting example: When cutting rib groove contours in hardened steel (50HRC) using an EPDBE2020-10-ATH tool:
 Cutting depth = $0.21 (a_p) \times 0.65$ (cutting depth factor for Group 5 hardened steel) $\times 0.8$ (for closed-area cutting) = 0.11mm

- [Note]**
- ① PN coating is less electro conductive. Therefore, electric transmitted measuring systems may not work.
 - ② Use the appropriate coolant for the work material and machining shape.
 - ③ These Recommended Cutting Conditions indicate only the rule of a thumb for the cutting conditions. In actual machining, the condition should be adjusted according to the machining shape, purpose and the machine type.
 - ④ If the rpm of the machine is low, lower the feed rate also to put the rpm and feed rate in the same ratio.

High efficiency
cutting condition

**High accuracy
cutting condition**

Please refer to P.10
about high efficiency cutting conditions

Epoch Deep Ball Evolution EPDBE-PN EPDBE-ATH

Recommended range				PN series											
				ATH series											
Work material				1		2		3		4		5		6	
				Coppers		Carbon steels, Alloy steels (180~250HB)		Stainless steels, Tool steels (25~35HRC)		Pre-hardened steels (35~45HRC)		Hardened steels (45~55HRC)		Hardened steels (55~65HRC)	
Ratio to standard depth of cut				120%		100%		90%		80%		65%		60%	
Ball radius RE (mm)	Tool dia. DC (mm)	Under neck length LU (mm)	a_p (mm)	Revolution n min ⁻¹	Feed rate v_f mm/min	Revolution n min ⁻¹	Feed rate v_f mm/min	Revolution n min ⁻¹	Feed rate v_f mm/min	Revolution n min ⁻¹	Feed rate v_f mm/min	Revolution n min ⁻¹	Feed rate v_f mm/min	Revolution n min ⁻¹	Feed rate v_f mm/min
0.05	0.1	0.2	0.004	50,000	300	50,000	250	50,000	250	50,000	225	50,000	200	50,000	188
		0.3	0.003	50,000	300	50,000	250	50,000	250	50,000	225	50,000	200	50,000	188
		0.5	0.002	50,000	300	50,000	250	50,000	250	50,000	225	50,000	200	50,000	188
0.1	0.2	0.5	0.015	50,000	420	50,000	350	50,000	350	50,000	325	45,500	273	42,000	210
		0.75	0.013	50,000	420	50,000	350	50,000	350	50,000	325	45,500	273	42,000	210
		1	0.011	50,000	420	50,000	350	50,000	350	50,000	325	45,500	273	42,000	210
		1.25	0.008	50,000	378	50,000	315	48,600	306	45,900	269	40,500	219	37,800	170
		1.5	0.007	50,000	378	50,000	315	48,600	306	45,900	269	40,500	219	37,800	170
		2	0.006	50,000	378	50,000	315	48,600	306	45,900	269	40,500	219	37,800	170
		2.5	0.005	48,000	323	48,000	269	43,200	242	40,800	212	36,000	173	33,600	134
		3	0.003	48,000	323	48,000	269	43,200	242	40,800	212	36,000	173	33,600	134
0.15	0.3	0.5	0.02	50,000	600	50,000	500	50,000	500	50,000	450	45,000	383	42,000	336
		0.75	0.018	50,000	600	50,000	500	50,000	500	50,000	450	45,000	383	42,000	336
		1	0.016	50,000	600	50,000	500	50,000	500	50,000	450	45,000	383	42,000	336
		1.25	0.014	50,000	600	50,000	500	50,000	500	50,000	450	45,000	383	42,000	336
		1.5	0.012	50,000	600	50,000	500	50,000	500	50,000	450	45,000	383	42,000	336
		2	0.009	50,000	540	50,000	450	48,600	437	45,900	372	40,500	310	37,800	272
		2.5	0.008	50,000	540	50,000	450	48,600	437	45,900	372	40,500	310	37,800	272
		3	0.006	50,000	540	50,000	450	48,600	437	45,900	372	40,500	310	37,800	272
0.2	0.4	0.75	0.043	50,000	691	48,000	576	43,200	518	40,800	449	36,000	360	33,600	336
		1	0.04	50,000	691	48,000	576	43,200	518	40,800	449	36,000	360	33,600	336
		1.5	0.034	50,000	691	48,000	576	43,200	518	40,800	449	36,000	360	33,600	336
		2	0.028	50,000	691	48,000	576	43,200	518	40,800	449	36,000	360	33,600	336
		2.5	0.016	50,000	560	43,200	467	38,880	420	36,720	364	32,400	292	30,240	272
		3	0.011	50,000	560	43,200	467	38,880	420	36,720	364	32,400	292	30,240	272
		3.5	0.008	50,000	560	43,200	467	38,880	420	36,720	364	32,400	292	30,240	272
		4	0.005	50,000	560	43,200	467	38,880	420	36,720	364	32,400	292	30,240	272
0.25	0.5	4.5	0.004	46,080	470	38,400	392	34,560	353	32,640	305	28,800	245	26,880	228
		1	0.045	48,000	960	40,000	800	36,000	720	34,000	612	30,000	540	28,000	476
		1.5	0.04	48,000	960	40,000	800	36,000	720	34,000	612	30,000	540	28,000	476
		2	0.035	48,000	960	40,000	800	36,000	720	34,000	612	30,000	540	28,000	476
		2.5	0.033	43,200	778	40,000	800	32,400	583	30,600	496	27,000	437	25,200	386
		3	0.03	43,200	778	36,000	648	32,400	583	30,600	496	27,000	437	25,200	386
		4	0.02	43,200	778	36,000	648	32,400	583	30,600	496	27,000	437	25,200	386
		5	0.018	43,200	778	36,000	648	32,400	583	30,600	496	27,000	437	25,200	386
0.3	0.6	5.5	0.008	38,400	653	32,000	544	28,800	490	27,200	416	24,000	367	22,400	324
		6	0.007	38,400	653	32,000	544	28,800	490	27,200	416	24,000	367	22,400	324
		8	0.004	38,400	653	32,000	544	28,800	490	27,200	416	24,000	367	22,400	324
		1	0.05	48,000	1,440	40,000	1,200	36,000	1,080	34,000	884	30,000	720	28,000	560
		2	0.042	48,000	1,440	40,000	1,200	36,000	1,080	34,000	884	30,000	720	28,000	560
		2.5	0.038	48,000	1,440	40,000	1,200	36,000	1,080	34,000	884	30,000	720	28,000	560
		3	0.034	48,000	1,440	40,000	1,200	36,000	1,080	34,000	884	30,000	720	28,000	560
		3.5	0.029	43,200	1,231	36,000	1,026	32,400	923	30,600	756	27,000	616	25,200	479
		4	0.024	43,200	1,231	36,000	1,026	32,400	923	30,600	756	27,000	616	25,200	479
		4.5	0.022	43,200	1,166	36,000	972	32,400	875	30,600	716	27,000	583	25,200	454
		5	0.02	43,200	1,166	36,000	972	32,400	875	30,600	716	27,000	583	25,200	454
		5.5	0.017	43,200	1,166	36,000	972	32,400	875	30,600	716	27,000	583	25,200	454
0.35	0.7	6	0.015	43,200	1,166	36,000	972	32,400	875	30,600	716	27,000	583	25,200	454
		7	0.008	38,400	979	32,000	816	28,800	734	27,200	601	24,000	490	22,400	381
		8	0.008	38,400	979	32,000	816	28,800	734	27,200	601	24,000	490	22,400	381
		9	0.006	38,400	979	32,000	816	28,800	734	27,200	601	24,000	490	22,400	381
		10	0.005	33,600	857	28,000	714	25,200	643	23,800	526	21,000	428	19,600	333
		12	0.004	28,800	691	24,000	576	21,600	518	20,400	424	18,000	346	16,800	269
		2	0.061	48,000	1,584	40,000	1,320	36,000	1,188	34,000	977	30,000	805	28,000	660
		4	0.034	43,200	1,354	36,000	1,128	32,400	1,015	30,600	835	27,000	688	25,200	564
6	0.027	43,200	1,283	36,000	1,069	32,400	962	30,600	791	27,000	652	25,200	535		
8	0.01	38,400	1,013	32,000	844	28,800	760	27,200	625	24,000	515	22,400	422		

[Note] Please refer to P.15

Features
Ball/PN Coating
Dimensions
Ball/ATH Coating
Cutting condition
Ball/High efficiency
Cutting condition
Ball/High accuracy
Dimensions
Square/PN Coating
Dimensions
Square/ATH Coating
Cutting condition
Square/High efficiency
Cutting condition
Square/High accuracy
Technical Data

Recommended Cutting Conditions

High efficiency cutting condition

High accuracy cutting condition

Please refer to P.10 about high efficiency cutting conditions

Epoch Deep Ball Evolution **EPDBE-PN** **EPDBE-ATH**

Recommended range		PN series													
		ATH series													
Work material		1		2		3		4		5		6			
		Coppers		Carbon steels, Alloy steels (180~250HB)		Stainless steels, Tool steels (25~35HRC)		Pre-hardened steels (35~45HRC)		Hardened steels (45~55HRC)		Hardened steels (55~65HRC)			
Ratio to standard depth of cut		120%		100%		90%		80%		65%		60%			
Ball radius RE (mm)	Tool dia. DC (mm)	Under neck length LU (mm)	ap (mm)	Revolution n min ⁻¹	Feed rate vf mm/min	Revolution n min ⁻¹	Feed rate vf mm/min	Revolution n min ⁻¹	Feed rate vf mm/min	Revolution n min ⁻¹	Feed rate vf mm/min	Revolution n min ⁻¹	Feed rate vf mm/min	Revolution n min ⁻¹	Feed rate vf mm/min
0.4	0.8	2	0.08	48,000	1,728	40,000	1,440	36,000	1,296	34,000	1,088	30,000	900	28,000	784
		4	0.056	48,000	1,728	40,000	1,440	36,000	1,296	34,000	1,088	30,000	900	28,000	784
		5	0.045	43,200	1,400	36,000	1,166	32,400	1,050	30,600	881	27,000	729	25,200	635
		6	0.032	43,200	1,400	36,000	1,166	32,400	1,050	30,600	881	27,000	729	25,200	635
		8	0.02	38,400	1,244	32,000	1,037	28,800	933	27,200	783	24,000	648	22,400	564
0.45	0.9	10	0.01	38,400	1,175	32,000	979	28,800	881	27,200	740	24,000	612	22,400	533
		2	0.09	45,600	1,944	38,000	1,620	34,200	1,458	32,300	1,215	28,500	1,004	26,600	891
		4	0.058	45,600	1,944	38,000	1,620	34,200	1,458	32,300	1,215	28,500	1,004	26,600	891
		6	0.042	41,040	1,574	34,200	1,312	30,780	1,181	29,070	984	25,650	813	23,940	722
0.5	1	8	0.03	36,480	1,399	30,400	1,166	27,360	1,049	25,840	875	22,800	723	21,280	641
		2	0.1	43,200	2,160	36,000	1,800	32,400	1,620	30,600	1,377	27,000	1,134	25,200	1,008
		3	0.1	43,200	2,160	36,000	1,800	32,400	1,620	30,600	1,377	27,000	1,134	25,200	1,008
		4	0.07	43,200	2,160	36,000	1,800	32,400	1,620	30,600	1,377	27,000	1,134	25,200	1,008
		5	0.06	43,200	2,160	36,000	1,800	32,400	1,620	30,600	1,377	27,000	1,134	25,200	1,008
		6	0.04	38,880	1,750	32,400	1,458	29,160	1,312	27,540	1,115	24,300	919	22,680	816
		7	0.04	38,880	1,750	32,400	1,458	29,160	1,312	27,540	1,115	24,300	919	22,680	816
		8	0.04	38,880	1,750	32,400	1,458	29,160	1,312	27,540	1,115	24,300	919	22,680	816
		9	0.03	38,880	1,750	32,400	1,458	29,160	1,312	27,540	1,115	24,300	919	22,680	816
		10	0.025	38,880	1,750	32,400	1,458	29,160	1,312	27,540	1,115	24,300	919	22,680	816
		12	0.013	34,560	1,469	28,800	1,224	25,920	1,102	24,480	936	21,600	771	20,160	685
		13	0.011	34,560	1,469	28,800	1,224	25,920	1,102	24,480	936	21,600	771	20,160	685
		14	0.01	34,560	1,469	28,800	1,224	25,920	1,102	24,480	936	21,600	771	20,160	685
		16	0.008	34,560	1,469	28,800	1,224	25,920	1,102	24,480	936	21,600	771	20,160	685
		18	0.006	30,240	1,210	25,200	1,008	22,680	907	21,420	771	18,900	635	17,640	564
		20	0.005	25,920	1,037	21,600	864	19,440	778	18,360	661	16,200	544	15,120	484
0.55	1.1	2	0.1	40,320	2,110	33,600	1,758	30,240	1,582	28,560	1,301	25,200	1,090	23,520	967
		4	0.07	40,320	2,110	33,600	1,758	30,240	1,582	28,560	1,301	25,200	1,090	23,520	967
		6	0.04	36,720	1,774	30,600	1,478	27,540	1,330	26,010	1,094	22,950	916	21,420	813
		8	0.04	36,720	1,774	30,600	1,478	27,540	1,330	26,010	1,094	22,950	916	21,420	813
		10	0.025	36,720	1,774	30,600	1,478	27,540	1,330	26,010	1,094	22,950	916	21,420	813
0.6	1.2	4	0.08	36,923	1,932	30,769	1,610	27,692	1,449	26,154	1,208	23,077	998	21,538	886
		6	0.06	34,560	1,797	28,800	1,498	25,920	1,348	24,480	1,102	21,600	950	20,160	806
		8	0.04	34,560	1,797	28,800	1,498	25,920	1,348	24,480	1,102	21,600	950	20,160	806
		10	0.035	34,560	1,617	28,800	1,423	25,920	1,213	24,480	1,102	21,600	855	20,160	726
0.7	1.4	12	0.03	34,560	1,617	28,800	1,348	25,920	1,213	24,480	1,102	21,600	855	20,160	726
		8	0.055	30,240	1,814	25,200	1,512	22,680	1,361	21,420	1,157	18,900	983	17,640	882
		12	0.035	30,240	1,633	25,200	1,361	22,680	1,225	21,420	1,041	18,900	885	17,640	794
		16	0.017	26,880	1,371	22,400	1,142	20,160	1,028	19,040	874	16,800	743	15,680	666
0.75	1.5	4	0.1	33,600	2,218	28,000	1,848	25,200	1,663	23,800	1,428	21,000	1,134	19,600	980
		6	0.1	33,600	2,218	28,000	1,848	25,200	1,663	23,800	1,428	21,000	1,134	19,600	980
		8	0.06	30,240	1,796	25,200	1,497	22,680	1,347	21,420	1,157	18,900	919	17,640	794
		10	0.06	30,240	1,796	25,200	1,497	22,680	1,347	21,420	1,157	18,900	919	17,640	794
		12	0.06	30,240	1,796	25,200	1,497	22,680	1,347	21,420	1,157	18,900	919	17,640	794
		14	0.05	26,880	1,508	25,200	1,497	20,160	1,131	19,040	971	16,800	771	15,680	666
		16	0.019	26,880	1,508	22,400	1,257	20,160	1,131	19,040	971	16,800	771	15,680	666
		18	0.019	26,880	1,508	22,400	1,257	20,160	1,131	19,040	971	16,800	771	15,680	666
0.8	1.6	20	0.019	26,880	1,508	22,400	1,257	20,160	1,131	19,040	971	16,800	771	15,680	666
		8	0.11	31,200	2,184	26,000	1,820	23,400	1,638	22,100	1,370	19,500	1,170	18,200	1,019
		12	0.065	28,080	1,769	23,400	1,474	21,060	1,327	19,890	1,110	17,550	948	16,380	826
		16	0.04	28,080	1,769	23,400	1,474	21,060	1,327	19,890	1,110	17,550	948	16,380	826
0.9	1.8	20	0.02	24,960	1,485	20,800	1,238	18,720	1,114	17,680	932	15,600	796	14,560	693
		8	0.13	31,200	2,496	26,000	2,080	23,400	1,872	22,100	1,547	19,500	1,287	18,200	1,092
		12	0.07	28,080	2,022	23,400	1,685	21,060	1,516	19,890	1,253	17,550	1,042	16,380	885
		16	0.045	28,080	2,022	23,400	1,685	21,060	1,516	19,890	1,253	17,550	1,042	16,380	885
1	2	20	0.022	24,960	1,697	20,800	1,414	18,720	1,273	17,680	1,052	15,600	875	14,560	743
		3	0.2	25,200	2,520	21,000	2,100	18,900	1,890	17,850	1,607	15,750	1,355	14,700	1,176
		4	0.2	25,200	2,520	21,000	2,100	18,900	1,890	17,850	1,607	15,750	1,355	14,700	1,176
		6	0.2	25,200	2,268	21,000	1,890	18,900	1,701	17,850	1,428	15,750	1,197	14,700	1,058
		8	0.14	25,200	2,268	21,000	1,890	18,900	1,701	17,850	1,428	15,750	1,197	14,700	1,058
10	0.14	25,200	2,016	21,000	1,680	18,900	1,512	17,850	1,285	15,750	1,071	14,700	941		

Recommended range				PN series											
				ATH series											
Work material				1		2		3		4		5		6	
				Coppers		Carbon steels, Alloy steels (180~250HB)		Stainless steels, Tool steels (25~35HRC)		Pre-hardened steels (35~45HRC)		Hardened steels (45~55HRC)		Hardened steels (55~65HRC)	
Ratio to standard depth of cut				120%		100%		90%		80%		65%		60%	
Ball radius RE (mm)	Tool dia. DC (mm)	Under neck length LU (mm)	a_p (mm)	Revolution n min ⁻¹	Feed rate v_f mm/min	Revolution n min ⁻¹	Feed rate v_f mm/min	Revolution n min ⁻¹	Feed rate v_f mm/min	Revolution n min ⁻¹	Feed rate v_f mm/min	Revolution n min ⁻¹	Feed rate v_f mm/min	Revolution n min ⁻¹	Feed rate v_f mm/min
1	2	12	0.08	22,680	1,814	18,900	1,512	17,010	1,361	16,065	1,157	14,175	964	13,230	847
		13	0.08	22,680	1,814	18,900	1,512	17,010	1,361	16,065	1,157	14,175	964	13,230	847
		14	0.08	22,680	1,814	18,900	1,512	17,010	1,361	16,065	1,157	14,175	964	13,230	847
		16	0.08	22,680	1,633	18,900	1,361	17,010	1,225	16,065	1,041	14,175	868	13,230	762
		18	0.06	22,680	1,633	18,900	1,361	17,010	1,225	16,065	1,041	14,175	868	13,230	762
		20	0.05	22,680	1,633	18,900	1,361	17,010	1,225	16,065	1,041	14,175	868	13,230	762
		22	0.042	21,420	1,457	17,850	1,214	16,065	1,092	15,173	929	13,388	774	12,495	680
		25	0.035	20,160	1,371	16,800	1,142	15,120	1,028	14,280	874	12,600	728	11,760	640
		30	0.015	20,160	1,371	16,800	1,142	15,120	1,028	14,280	874	12,600	728	11,760	640
		35	0.012	17,640	1,129	14,700	941	13,230	847	12,495	720	11,025	600	10,290	527
		40	0.01	15,120	968	12,600	806	11,340	726	10,710	617	9,450	514	8,820	452
1.25	2.5	6	0.25	22,200	2,700	18,500	2,250	16,650	2,025	15,725	1,688	13,875	1,373	12,950	1,125
		10	0.17	22,200	2,700	18,500	2,250	16,650	2,025	15,725	1,688	13,875	1,373	12,950	1,125
		15	0.1	19,980	2,186	16,650	1,822	14,985	1,640	14,153	1,367	12,488	1,111	11,655	911
		20	0.08	19,980	2,186	16,650	1,822	14,985	1,640	14,153	1,367	12,488	1,111	11,655	911
		25	0.065	19,980	1,967	16,650	1,639	14,985	1,475	14,153	1,229	12,488	1,000	11,655	820
		30	0.044	17,760	1,836	14,800	1,530	13,320	1,377	12,580	1,148	11,100	933	10,360	765
1.5	3	8	0.3	19,200	2,880	16,000	2,400	14,400	2,160	13,600	1,822	12,000	1,512	11,200	1,344
		10	0.21	19,200	2,880	16,000	2,400	14,400	2,160	13,600	1,822	12,000	1,512	11,200	1,344
		13	0.21	19,200	2,880	16,000	2,400	14,400	2,160	13,600	1,822	12,000	1,512	11,200	1,344
		16	0.21	19,200	2,592	16,000	2,160	14,400	1,944	13,600	1,640	12,000	1,361	11,200	1,210
		20	0.12	17,280	2,333	14,400	1,944	12,960	1,750	12,240	1,476	10,800	1,225	10,080	1,089
		25	0.08	17,280	2,333	14,400	1,944	12,960	1,750	12,240	1,476	10,800	1,225	10,080	1,089
		30	0.08	17,280	2,333	14,400	1,944	12,960	1,750	12,240	1,476	10,800	1,225	10,080	1,089
		35	0.064	15,360	1,958	12,800	1,632	11,520	1,469	10,880	1,239	9,600	1,028	8,960	914
1.75	3.5	15	0.24	16,500	2,820	13,750	2,350	12,375	2,115	11,688	1,763	10,313	1,434	9,625	1,175
		25	0.14	14,850	2,280	12,375	1,900	11,138	1,710	10,519	1,425	9,281	1,159	8,663	950
		35	0.09	14,850	2,280	12,375	1,900	11,138	1,710	10,519	1,425	9,281	1,159	8,663	950
		45	0.072	13,200	1,918	11,000	1,598	9,900	1,438	9,350	1,199	8,250	975	7,700	799
2	4	10	0.4	13,800	2,760	11,500	2,300	10,350	2,070	9,775	1,760	8,625	1,466	8,050	1,288
		13	0.32	13,800	2,760	11,500	2,300	10,350	2,070	9,775	1,760	8,625	1,466	8,050	1,288
		16	0.28	13,800	2,760	11,500	2,300	10,350	2,070	9,775	1,760	8,625	1,466	8,050	1,288
		20	0.28	13,800	2,760	11,500	2,300	10,350	2,070	9,775	1,760	8,625	1,466	8,050	1,288
		25	0.16	12,420	2,236	10,350	1,863	9,315	1,677	8,798	1,425	7,763	1,188	7,245	1,043
		30	0.16	12,420	2,236	10,350	1,863	9,315	1,677	8,798	1,425	7,763	1,188	7,245	1,043
		35	0.1	12,420	2,236	10,350	1,863	9,315	1,677	8,798	1,425	7,763	1,188	7,245	1,043
		40	0.1	12,420	2,236	10,350	1,863	9,315	1,677	8,798	1,425	7,763	1,188	7,245	1,043
		45	0.08	11,040	1,877	9,200	1,564	8,280	1,408	7,820	1,196	6,900	997	6,440	876
		50	0.07	11,040	1,877	9,200	1,564	8,280	1,408	7,820	1,196	6,900	997	6,440	876
2.5	5	20	0.35	10,800	2,592	9,000	2,160	8,100	1,944	7,650	1,530	6,750	1,350	6,300	1,134
		25	0.35	10,800	2,592	9,000	2,160	8,100	1,944	7,650	1,530	6,750	1,350	6,300	1,134
		30	0.2	9,720	2,333	8,100	1,944	7,290	1,750	6,885	1,377	6,075	1,215	5,670	1,021
		40	0.2	9,720	2,100	8,100	1,750	7,290	1,575	6,885	1,239	6,075	1,094	5,670	919
3	6	12	0.6	10,800	3,024	9,000	2,520	8,100	2,268	7,650	1,890	6,750	1,537	6,300	1,260
		20	0.5	10,200	2,652	8,500	2,210	7,650	1,989	7,225	1,658	6,375	1,348	5,950	1,105
		30	0.42	9,600	2,304	8,000	1,920	7,200	1,728	6,800	1,360	6,000	1,200	5,600	1,008
		50	0.15	8,640	1,866	7,200	1,555	6,480	1,400	6,120	1,102	5,400	972	5,040	816

- ※(1) a_p is shown as the criteria for Group 2 workpieces. For other groups, adjust the cutting depth according to the cutting depth factors in the above table.
 ※(2) When performing cutting where cutting chips may cause clogging, such as for rib processing, blind grooves, etc., cutting depth setting should be set by multiplying a cutting depth factor to calculate the cutting depth amount, and this amount should then be reduced to 80% of the calculated value.
 ※(3) Adjust by setting a_e to (3 to 5) × (a_p) × (cutting depth ratio). When performing finishing processing, calculate the theoretical cusp height and set accordingly.

Cutting depth setting example: When cutting rib groove contours in hardened steel (50HRC) using an EPDBE2020-10-ATH tool:
 Cutting depth = 0.14 (a_p) × 0.65 (cutting depth factor for Group 5 hardened steel) × 0.8 (for closed-area cutting) = 0.073mm

- [Note]**
- ① PN coating is less electro conductive. Therefore, electric transmitted measuring systems may not work.
 - ② Use the appropriate coolant for the work material and machining shape.
 - ③ These Recommended Cutting Conditions indicate only the rule of a thumb for the cutting conditions. In actual machining, the condition should be adjusted according to the machining shape, purpose and the machine type.
 - ④ If the rpm of the machine is low, lower the feed rate also to put the rpm and feed rate in the same ratio.

Features
 Dimensions
 Ball PN Coating
 Dimensions
 Ball ATH Coating
 Cutting condition
 Ball High efficiency
 Cutting condition
 Ball High accuracy
 Dimensions
 Square PN Coating
 Dimensions
 Square ATH Coating
 Cutting condition
 Square High efficiency
 Cutting condition
 Square High accuracy
 Technical Data

Line Up

Epoch Deep Square Evolution EPDSE-PN

PN Coating

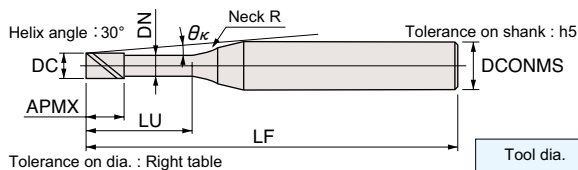

Tool dia.	Tolerance on dia.
φ 0.1~φ 0.5	0 -0.007
φ 0.6~φ 0.9	0 -0.01
φ 1~φ 6	0 -0.015

EPDSE2000-0.0.0-PN

Item code	Stock PN	Size(mm)								The effective under-neck length for the various draft angles				
		Tool dia.	Under neck length	Flute length	Neck dia.	Overall length	Shank dia.	Neck R	Interference angle	0.5°	1°	1.5°	2°	3°
		DC	LU	APMX	DN	LF	DCONMS	θκ						
EPDSE2001-0.3-PN	●	0.1	0.3	0.15	0.08	45	4	1	11.58	0.46	0.49	0.51	0.53	0.58
EPDSE2001-0.5-PN	●		0.5						11.35	0.67	0.71	0.74	0.76	0.82
EPDSE2001-1-PN	●		1						10.81	1.20	1.25	1.29	1.33	1.39
EPDSE2002-0.5-PN	●	0.2	0.5	0.3	0.17	50	4	1	11.30	0.70	0.73	0.76	0.78	0.83
EPDSE2002-1-PN	●		1						10.75	1.22	1.27	1.31	1.34	1.42
EPDSE2002-1.5-PN	●		1.5						10.25	1.74	1.80	1.85	1.89	2.08
EPDSE2002-2-PN	●	0.3	2	0.45	0.27	50	4	2	9.80	2.26	2.32	2.38	2.47	2.74
EPDSE2002-3-PN	●		3						9.00	3.29	3.37	3.50	3.67	4.07
EPDSE2003-1-PN	●		1						10.72	1.32	1.39	1.45	1.51	1.62
EPDSE2003-1.5-PN	●	0.4	1.5	0.6	0.37	50	4	2	10.69	1.32	1.39	1.45	1.51	1.62
EPDSE2003-2-PN	●		2						10.21	1.85	1.93	2.01	2.08	2.21
EPDSE2003-2.5-PN	●		2.5						9.75	2.37	2.47	2.56	2.64	2.78
EPDSE2003-3-PN	●	0.5	3	0.75	0.47	50	4	2	9.32	2.89	3.01	3.11	3.20	3.41
EPDSE2004-1-PN	●		1						8.93	3.42	3.54	3.65	3.75	4.07
EPDSE2004-1.5-PN	●		1.5						10.69	1.32	1.39	1.45	1.51	1.62
EPDSE2004-2-PN	●	0.6	2	0.9	0.57	50	4	4	10.17	1.85	1.93	2.01	2.08	2.21
EPDSE2004-2.5-PN	●		2.5						9.70	2.37	2.47	2.56	2.64	2.78
EPDSE2004-3-PN	●		3						9.27	2.89	3.01	3.11	3.20	3.41
EPDSE2004-3.5-PN	●	0.7	3.5	1.05	0.67	50	4	4	8.87	3.42	3.54	3.65	3.75	4.07
EPDSE2004-4-PN	●		4						8.51	3.94	4.08	4.19	4.29	4.73
EPDSE2004-5-PN	●		5						8.17	4.46	4.61	4.73	4.87	5.40
EPDSE2004-6-PN	●	0.8	6	1.05	0.67	50	4	4	7.58	5.49	5.66	5.79	6.06	6.72
EPDSE2004-8-PN	●		8						7.06	6.53	6.71	6.92	7.26	8.05
EPDSE2004-10-PN	●		10						6.22	8.59	8.80	9.20	9.65	10.71
EPDSE2005-1-PN	●	0.9	1	1.05	0.67	50	4	4	5.55	10.64	10.97	11.48	12.05	13.36
EPDSE2005-1.5-PN	●		1.5						10.66	1.32	1.39	1.45	1.51	1.62
EPDSE2005-2-PN	●		2						10.13	1.85	1.93	2.01	2.08	2.21
EPDSE2005-2.5-PN	●	1.0	2.5	1.05	0.67	50	4	4	9.64	2.37	2.47	2.56	2.64	2.78
EPDSE2005-3-PN	●		3						9.21	2.89	3.01	3.11	3.20	3.41
EPDSE2005-4-PN	●		4						8.81	3.42	3.54	3.65	3.75	4.07
EPDSE2005-5-PN	●	1.1	5	1.05	0.67	50	4	4	8.10	4.46	4.61	4.73	4.87	5.40
EPDSE2005-6-PN	●		6						7.50	5.49	5.66	5.79	6.06	6.72
EPDSE2005-8-PN	●		8						6.98	6.53	6.71	6.92	7.26	8.05
EPDSE2005-10-PN	●	1.2	10	1.05	0.67	50	4	4	6.13	8.59	8.80	9.20	9.65	10.71
EPDSE2006-2-PN	●		2						5.47	10.64	10.97	11.48	12.05	13.36
EPDSE2006-3-PN	●		3						9.59	2.54	2.70	2.84	2.96	3.19
EPDSE2006-4-PN	●	1.3	4	1.05	0.67	50	4	4	8.74	3.60	3.80	3.96	4.11	4.37
EPDSE2006-5-PN	●		5						8.02	4.66	4.89	5.07	5.24	5.53
EPDSE2006-6-PN	●		6						7.42	5.71	5.96	6.17	6.35	6.72
EPDSE2006-7-PN	●	1.4	7	1.05	0.67	50	4	4	6.90	6.76	7.04	7.26	7.45	8.05
EPDSE2006-8-PN	●		8						6.44	7.81	8.10	8.34	8.55	9.38
EPDSE2006-9-PN	●		9						6.04	8.85	9.17	9.42	9.65	10.71
EPDSE2006-10-PN	●	1.5	10	1.05	0.67	50	4	4	5.69	9.89	10.22	10.49	10.85	12.03
EPDSE2007-2-PN	●		2						5.38	10.93	11.28	11.56	12.05	13.36
EPDSE2007-4-PN	●		4						9.53	2.54	2.70	2.84	2.96	3.19
EPDSE2007-6-PN	●	1.6	6	1.05	0.67	50	4	4	7.94	4.66	4.89	5.07	5.24	5.53
EPDSE2007-8-PN	●		8						6.81	6.76	7.04	7.26	7.45	8.05
EPDSE2007-10-PN	●		10						5.95	8.85	9.17	9.42	9.65	10.71

● : Stocked items.

Detailed shape below neck

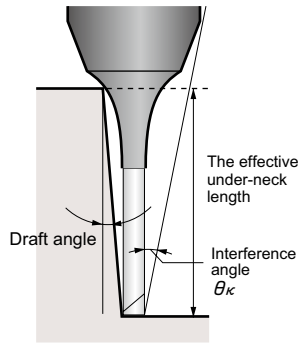
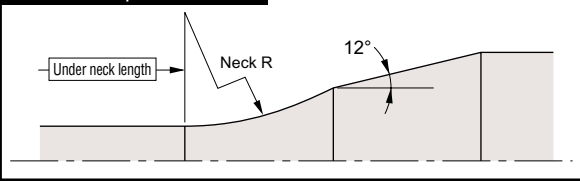

[Note]

The effective under-neck length is different from Epoch Deep Square EPDS. Please recheck the interference region.

EPDSE2-000-000-PN

Item code	Stock PN	Size(mm)								The effective under-neck length for the various draft angles				
		Tool dia. DC	Under neck length LU	Flute length APMX	Neck dia. DN	Overall length LF	Shank dia. DCONMS	Neck R	Interference angle $\theta\kappa$	0.5°	1°	1.5°	2°	3°
EPDSE2008-2-PN	●	0.8	2	1.2	0.77	50	4	4	9.47	2.54	2.70	2.84	2.96	3.19
EPDSE2008-4-PN	●		4						7.86	4.66	4.89	5.07	5.24	5.53
EPDSE2008-6-PN	●		6						6.72	6.76	7.04	7.26	7.45	8.05
EPDSE2008-8-PN	●		8						5.86	8.85	9.17	9.42	9.65	10.71
EPDSE2008-10-PN	●		10						5.20	10.93	11.28	11.56	12.05	13.36
EPDSE2008-12-PN	●		12						4.67	13.00	13.38	13.76	14.44	16.02
EPDSE2009-2-PN	●	0.9	2	1.35	0.86	50	4	4	9.38	2.58	2.73	2.86	2.98	3.21
EPDSE2009-4-PN	●		4						7.76	4.69	4.91	5.09	5.26	5.54
EPDSE2009-6-PN	●		6						6.61	6.79	7.06	7.28	7.47	8.08
EPDSE2009-8-PN	●		8						5.76	8.87	9.18	9.43	9.68	10.74
EPDSE2009-10-PN	●		10						5.10	10.95	11.30	11.57	12.07	13.39
EPDSE2009-12-PN	●		12						4.58	13.02	13.40	13.79	14.47	16.05
EPDSE2010-2-PN	●	1	2	1.5	0.96	50	4	4	9.31	2.58	2.73	2.86	2.98	3.21
EPDSE2010-3-PN	●		3						8.41	3.64	3.82	3.99	4.13	4.39
EPDSE2010-4-PN	●		4						7.67	4.69	4.91	5.09	5.26	5.54
EPDSE2010-5-PN	●		5						7.04	5.74	5.99	6.19	6.37	6.76
EPDSE2010-6-PN	●		6						6.51	6.79	7.06	7.28	7.47	8.08
EPDSE2010-7-PN	●		7						6.06	7.83	8.12	8.36	8.56	9.41
EPDSE2010-8-PN	●		8						5.66	8.87	9.18	9.43	9.68	10.74
EPDSE2010-9-PN	●		9			5.31			9.91	10.24	10.50	10.88	12.07	
EPDSE2010-10-PN	●		10			5.00			10.95	11.30	11.57	12.07	13.39	
EPDSE2010-12-PN	●		12			4.48			13.02	13.40	13.79	14.47	16.05	
EPDSE2010-14-PN	●		14			4.06			15.09	15.49	16.07	16.86	18.70	
EPDSE2010-16-PN	●		16			3.71			17.15	17.58	18.35	19.25	21.36	
EPDSE2010-20-PN	●		20			3.17			21.26	21.89	22.91	24.04	26.66	
EPDSE2010-25-PN	●		25			2.68			26.39	27.33	28.61	30.02	No interference	
EPDSE2012-4-PN	●	1.2	4	1.8	1.15	50	4	4	7.46	4.72	4.93	5.11	5.27	5.55
EPDSE2012-6-PN	●		6						6.29	6.81	7.08	7.29	7.48	8.11
EPDSE2012-8-PN	●		8						5.44	8.90	9.20	9.45	9.71	10.77
EPDSE2012-10-PN	●		10						4.80	10.97	11.31	11.58	12.10	13.42
EPDSE2012-12-PN	●		12						4.29	13.04	13.41	13.82	14.49	16.08
EPDSE2012-16-PN	●		16						3.53	17.16	17.59	18.38	19.28	21.39
EPDSE2014-6-PN	●	1.4	6	2.1	1.34	50	4	4	6.06	6.84	7.09	7.31	7.50	8.15
EPDSE2014-12-PN	●		12			55			4.08	13.06	13.43	13.84	14.52	16.11
EPDSE2015-4-PN	●	1.5	4	2.25	1.44	50	4	4	7.11	4.75	4.95	5.13	5.29	5.57
EPDSE2015-6-PN	●		6						5.94	6.84	7.09	7.31	7.50	8.15
EPDSE2015-8-PN	●		8						5.10	8.92	9.22	9.46	9.74	10.80
EPDSE2015-10-PN	●		10						4.47	10.99	11.33	11.59	12.13	13.45
EPDSE2015-12-PN	●		12						3.97	13.06	13.43	13.84	14.52	16.11
EPDSE2015-14-PN	●		14						3.58	15.12	15.52	16.12	16.92	18.76
EPDSE2015-16-PN	●		16						3.25	17.18	17.60	18.40	19.31	21.42
EPDSE2015-18-PN	●		18			2.98			19.24	19.76	20.69	21.70	No interference	
EPDSE2015-20-PN	●		20			2.76			21.29	21.94	22.97	24.10	No interference	
EPDSE2015-25-PN	●		25			2.31			26.42	27.39	28.67	30.08	No interference	
EPDSE2015-30-PN	●		30			1.99			31.53	32.83	34.37	No interference	No interference	
EPDSE2015-35-PN	●		35			1.75			36.64	38.28	40.07	No interference	No interference	
EPDSE2015-40-PN	●		40			1.56			41.85	43.73	45.78	No interference	No interference	
EPDSE2016-6-PN	●		1.6			6			2.4	1.54	50	4	4	5.82
EPDSE2016-8-PN	●	8		4.98	8.92	9.22	9.46	9.74						10.80
EPDSE2018-6-PN	●	1.8	6	2.7	1.73	50	4	4	5.55	6.86	7.11	7.32	7.51	8.18
EPDSE2018-8-PN	●		8						4.72	8.94	9.23	9.47	9.76	10.83

● : Stocked items.

Features

Dimensions
Ball PN Coating

Dimensions
Ball ATH Coating

Cutting condition
Ball High efficiency

Cutting condition
Ball High accuracy

Dimensions
Square PN Coating

Dimensions
Square ATH Coating

Cutting condition
Square High efficiency

Cutting condition
Square High accuracy

Technical Data

Line Up

Epoch Deep Square Evolution

EPDSE-PN

PN Coating

2 Flutes

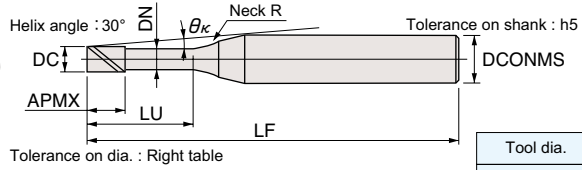

Tool dia.	Tolerance on dia.
φ 0.1~φ 0.5	-0.007
φ 0.6~φ 0.9	-0.01
φ 1~φ 6	-0.015

EPDSE2000-0000-PN

Item code	Stock PN	Size(mm)							The effective under-neck length for the various draft angles									
		Tool dia.	Under neck length	Flute length	Neck dia.	Overall length	Shank dia.	Neck R	Interference angle θ_K	0.5°	1°	1.5°	2°	3°				
		DC	LU	APMX	DN	LF	DCONMS											
EPDSE2020-4-PN	●	2	4	3	1.92	50	4	4	6.42	4.80	5.00	5.17	5.32	5.59				
EPDSE2020-6-PN	●		6						5.25	6.88	7.13	7.34	7.52	8.21				
EPDSE2020-8-PN	●		8						4.44	8.96	9.25	9.49	9.79	10.86				
EPDSE2020-10-PN	●		10						3.85	11.03	11.35	11.62	12.19	13.52				
EPDSE2020-12-PN	●		12						3.39	13.10	13.45	13.90	14.58	16.17				
EPDSE2020-14-PN	●		14			3.03			15.16	15.54	16.18	16.97	18.83					
EPDSE2020-16-PN	●		16			2.75			17.21	17.63	18.46	19.37	No interference	No interference	No interference	No interference	No interference	
EPDSE2020-18-PN	●		18			2.51			19.27	19.81	20.74	21.76	No interference	No interference	No interference	No interference	No interference	
EPDSE2020-20-PN	●		20			2.31			21.32	21.99	23.02	24.15	No interference	No interference	No interference	No interference	No interference	
EPDSE2020-25-PN	●		25			1.92			26.44	27.44	28.72	No interference	No interference	No interference	No interference	No interference	No interference	
EPDSE2020-30-PN	●		30			1.65			31.55	32.88	34.42	No interference	No interference	No interference	No interference	No interference	No interference	
EPDSE2020-35-PN	●		35			1.44			36.69	38.33	No interference	No interference	No interference	No interference	No interference	No interference	No interference	
EPDSE2020-40-PN	●		40			1.28			41.90	43.78	No interference	No interference	No interference	No interference	No interference	No interference	No interference	
EPDSE2020-50-PN	●		50			1.05			52.33	54.67	No interference	No interference	No interference	No interference	No interference	No interference	No interference	
EPDSE2025-8-PN	●		2.5			8			3.75	2.4	50	4	4	3.65	9.00	9.28	9.51	9.85
EPDSE2025-12-PN	●	12		2.73	13.13	13.48	13.95	14.64						No interference	No interference	No interference	No interference	No interference
EPDSE2025-16-PN	●	16		2.18	17.25	17.68	18.51	19.42						No interference	No interference	No interference	No interference	No interference
EPDSE2025-20-PN	●	20		1.81	21.35	22.04	23.07	No interference			No interference			No interference	No interference	No interference	No interference	
EPDSE2025-30-PN	●	30		1.28	31.58	32.94	No interference	No interference			No interference			No interference	No interference	No interference	No interference	
EPDSE2025-40-PN	●	40		0.99	41.95	No interference	No interference	No interference			No interference			No interference	No interference	No interference	No interference	
EPDSE2025-50-PN	●	50	0.80	52.38	No interference	No interference	No interference	No interference	No interference	No interference	No interference	No interference						
EPDSE2030-8-PN	●	3	8	4.5	2.88	55	6	4	5.59	9.04	9.31	9.54	9.91	10.99				
EPDSE2030-12-PN	●		12			4.44			13.16	13.50	14.00	14.69	16.30					
EPDSE2030-16-PN	●		16			3.68			17.28	17.73	18.57	19.48	21.61					
EPDSE2030-20-PN	●		20			3.15			21.38	22.09	23.13	24.26	26.91					
EPDSE2030-25-PN	●		25			2.66			26.49	27.54	28.83	30.25	No interference	No interference	No interference	No interference	No interference	
EPDSE2030-30-PN	●		30			2.31			31.60	32.99	34.53	36.23	No interference	No interference	No interference	No interference	No interference	
EPDSE2030-40-PN	●		40			1.82			42.00	43.88	45.94	No interference	No interference	No interference	No interference	No interference	No interference	
EPDSE2030-50-PN	●	50	1.50	52.43	54.78	No interference	No interference	No interference	No interference	No interference	No interference	No interference						
EPDSE2040-12-PN	●	4	12	6	3.85	60	6	4	3.36	13.21	13.54	14.08	14.78	16.39				
EPDSE2040-16-PN	●		16						2.72	17.32	17.81	18.65	19.56	No interference	No interference	No interference	No interference	No interference
EPDSE2040-20-PN	●		20			2.29			21.42	22.17	23.21	24.35	No interference	No interference	No interference	No interference	No interference	
EPDSE2040-25-PN	●		25			1.91			26.53	27.62	28.91	No interference	No interference	No interference	No interference	No interference	No interference	
EPDSE2040-30-PN	●		30			1.64			31.65	33.06	34.61	No interference	No interference	No interference	No interference	No interference	No interference	
EPDSE2040-35-PN	●		35			1.44			36.86	38.51	No interference	No interference	No interference	No interference	No interference	No interference	No interference	
EPDSE2040-40-PN	●		40			1.28			42.08	43.96	No interference	No interference	No interference	No interference	No interference	No interference	No interference	
EPDSE2040-50-PN	●		50			1.05			52.50	54.85	No interference	No interference	No interference	No interference	No interference	No interference	No interference	
EPDSE2050-20-PN	●	5	20	7.5	4.85	70	6	4	1.27	21.42	22.17	No interference	No interference	No interference				
EPDSE2050-25-PN	●		25						1.04	26.53	27.62	No interference	No interference	No interference	No interference	No interference	No interference	No interference
EPDSE2050-30-PN	●		30			0.88			31.65	No interference	No interference	No interference	No interference	No interference	No interference	No interference	No interference	
EPDSE2050-40-PN	●		40			0.68			42.08	No interference	No interference	No interference	No interference	No interference	No interference	No interference	No interference	
EPDSE2050-50-PN	●		50			0.55			52.50	No interference	No interference	No interference	No interference	No interference	No interference	No interference	No interference	
EPDSE2060-20-PN	●	6	20	9	5.85	70	6	-	0	No interference	No interference	No interference	No interference	No interference				
EPDSE2060-30-PN	●		30			0			No interference	No interference	No interference	No interference	No interference	No interference	No interference	No interference	No interference	
EPDSE2060-40-PN	●		40			0			No interference	No interference	No interference	No interference	No interference	No interference	No interference	No interference	No interference	
EPDSE2060-50-PN	●		50			0			No interference	No interference	No interference	No interference	No interference	No interference	No interference	No interference	No interference	

● : Stocked items.

Features

Dimensions
Ball PN Coating

Dimensions
Ball ATH Coating

Cutting condition
Ball High efficiency

Cutting condition
Ball High accuracy

Dimensions
Square PN Coating

Dimensions
Square ATH Coating

Cutting condition
Square High efficiency

Cutting condition
Square High accuracy

Technical Data

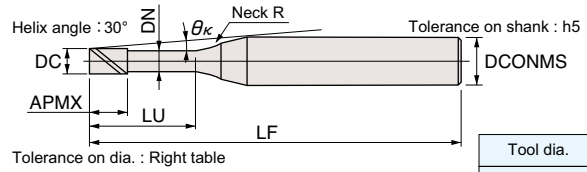

Tool dia.	Tolerance on dia.
φ0.1~φ0.5	-0.007
φ0.6~φ0.9	-0.01
φ1~φ6	-0.015

EPDSE2-ATH

Item code	Stock ATH	Size(mm)							The effective under-neck length for the various draft angles					
		Tool dia.	Under neck length	Flute length	Neck dia.	Overall length	Shank dia.	Neck R	Interference angle θκ	0.5°	1°	1.5°	2°	3°
		DC	LU	APMX	DN	LF	DCONMS							
EPDSE2001-0.3-ATH	●	0.1	0.3	0.15	0.08	45	4	1	11.58	0.46	0.49	0.51	0.53	0.58
EPDSE2001-0.5-ATH	●		0.5						11.35	0.67	0.71	0.74	0.76	0.82
EPDSE2001-1-ATH	●		1						10.81	1.20	1.25	1.29	1.33	1.39
EPDSE2002-0.5-ATH	●	0.2	0.5	0.3	0.17	50	4	1	11.30	0.70	0.73	0.76	0.78	0.83
EPDSE2002-1-ATH	●		1						10.75	1.22	1.27	1.31	1.34	1.42
EPDSE2002-1.5-ATH	●		1.5						10.25	1.74	1.80	1.85	1.89	2.08
EPDSE2002-2-ATH	●		2						9.80	2.26	2.32	2.38	2.47	2.74
EPDSE2002-3-ATH	●	3	9.00	3.29	3.37	3.50	3.67	4.07						
EPDSE2003-1-ATH	●	0.3	1	0.45	0.27	50	4	2	10.72	1.32	1.39	1.45	1.51	1.62
EPDSE2003-1.5-ATH	●		1.5						10.21	1.85	1.93	2.01	2.08	2.21
EPDSE2003-2-ATH	●		2						9.75	2.37	2.47	2.56	2.64	2.78
EPDSE2003-2.5-ATH	●		2.5						9.32	2.89	3.01	3.11	3.20	3.41
EPDSE2003-3-ATH	●		3						8.93	3.42	3.54	3.65	3.75	4.07
EPDSE2004-1-ATH	●	0.4	1	0.6	0.37	50	4	2	10.69	1.32	1.39	1.45	1.51	1.62
EPDSE2004-1.5-ATH	●		1.5						10.17	1.85	1.93	2.01	2.08	2.21
EPDSE2004-2-ATH	●		2						9.70	2.37	2.47	2.56	2.64	2.78
EPDSE2004-2.5-ATH	●		2.5						9.27	2.89	3.01	3.11	3.20	3.41
EPDSE2004-3-ATH	●		3						8.87	3.42	3.54	3.65	3.75	4.07
EPDSE2004-3.5-ATH	●		3.5						8.51	3.94	4.08	4.19	4.29	4.73
EPDSE2004-4-ATH	●		4						8.17	4.46	4.61	4.73	4.87	5.40
EPDSE2004-5-ATH	●		5						7.58	5.49	5.66	5.79	6.06	6.72
EPDSE2004-6-ATH	●		6						7.06	6.53	6.71	6.92	7.26	8.05
EPDSE2004-8-ATH	●		8						6.22	8.59	8.80	9.20	9.65	10.71
EPDSE2004-10-ATH	●	10	5.55	10.64	10.97	11.48	12.05	13.36						
EPDSE2005-1-ATH	●	0.5	1	0.75	0.47	50	4	2	10.66	1.32	1.39	1.45	1.51	1.62
EPDSE2005-1.5-ATH	●		1.5						10.13	1.85	1.93	2.01	2.08	2.21
EPDSE2005-2-ATH	●		2						9.64	2.37	2.47	2.56	2.64	2.78
EPDSE2005-2.5-ATH	●		2.5						9.21	2.89	3.01	3.11	3.20	3.41
EPDSE2005-3-ATH	●		3						8.81	3.42	3.54	3.65	3.75	4.07
EPDSE2005-4-ATH	●		4						8.10	4.46	4.61	4.73	4.87	5.40
EPDSE2005-5-ATH	●		5						7.50	5.49	5.66	5.79	6.06	6.72
EPDSE2005-6-ATH	●		6						6.98	6.53	6.71	6.92	7.26	8.05
EPDSE2005-8-ATH	●		8						6.13	8.59	8.80	9.20	9.65	10.71
EPDSE2005-10-ATH	●		10						5.47	10.64	10.97	11.48	12.05	13.36
EPDSE2006-2-ATH	●	0.6	2	0.9	0.57	50	4	4	9.59	2.54	2.70	2.84	2.96	3.19
EPDSE2006-3-ATH	●		3						8.74	3.60	3.80	3.96	4.11	4.37
EPDSE2006-4-ATH	●		4						8.02	4.66	4.89	5.07	5.24	5.53
EPDSE2006-5-ATH	●		5						7.42	5.71	5.96	6.17	6.35	6.72
EPDSE2006-6-ATH	●		6						6.90	6.76	7.04	7.26	7.45	8.05
EPDSE2006-7-ATH	●		7						6.44	7.81	8.10	8.34	8.55	9.38
EPDSE2006-8-ATH	●		8						6.04	8.85	9.17	9.42	9.65	10.71
EPDSE2006-9-ATH	●		9						5.69	9.89	10.22	10.49	10.85	12.03
EPDSE2006-10-ATH	●		10						5.38	10.93	11.28	11.56	12.05	13.36
EPDSE2007-2-ATH	●		0.7						2	1.05	0.67	50	4	4
EPDSE2007-4-ATH	●	4		7.94	4.66	4.89	5.07	5.24	5.53					
EPDSE2007-6-ATH	●	6		6.81	6.76	7.04	7.26	7.45	8.05					
EPDSE2007-8-ATH	●	8		5.95	8.85	9.17	9.42	9.65	10.71					
EPDSE2007-10-ATH	●	10		5.29	10.93	11.28	11.56	12.05	13.36					

● : Stocked items.

Features
Dimensions
Ball PN Coating
Dimensions
Ball ATH Coating
Cutting condition
Ball High efficiency
Cutting condition
Ball High accuracy
Dimensions
Square PN Coating
Dimensions
Square ATH Coating
Cutting condition
Square High efficiency
Cutting condition
Square High accuracy
Technical Data

Line Up

Epoch Deep Square Evolution

EPDSE-ATH



2 Flutes

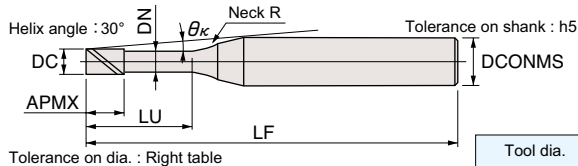

Tool dia.	Tolerance on dia.
φ 0.1~φ 0.5	0 -0.007
φ 0.6~φ 0.9	0 -0.01
φ 1~φ 6	0 -0.015

EPDSE2000-000-ATH

Item code	Stock ATH	Size(mm)							The effective under-neck length for the various draft angles					
		Tool dia. DC	Under neck length LU	Flute length APMX	Neck dia. DN	Overall length LF	Shank dia. DCONMS	Neck R	Interference angle θ_K	0.5°	1°	1.5°	2°	3°
		EPDSE2008-2-ATH	●	0.8	2	1.2	0.77	50	4	4	9.47	2.54	2.70	2.84
EPDSE2008-4-ATH	●	4	7.86		4.66						4.89	5.07	5.24	5.53
EPDSE2008-6-ATH	●	6	6.72		6.76						7.04	7.26	7.45	8.05
EPDSE2008-8-ATH	●	8	5.86		8.85						9.17	9.42	9.65	10.71
EPDSE2008-10-ATH	●	10	5.20		10.93						11.28	11.56	12.05	13.36
EPDSE2008-12-ATH	●	12	4.67		13.00						13.38	13.76	14.44	16.02
EPDSE2009-2-ATH	●	0.9	2	1.35	0.86	50	4	4	9.38	2.58	2.73	2.86	2.98	3.21
EPDSE2009-4-ATH	●		4						7.76	4.69	4.91	5.09	5.26	5.54
EPDSE2009-6-ATH	●		6						6.61	6.79	7.06	7.28	7.47	8.08
EPDSE2009-8-ATH	●		8						5.76	8.87	9.18	9.43	9.68	10.74
EPDSE2009-10-ATH	●		10						5.10	10.95	11.30	11.57	12.07	13.39
EPDSE2009-12-ATH	●		12						4.58	13.02	13.40	13.79	14.47	16.05
EPDSE2010-2-ATH	●	1	2	1.5	0.96	50	4	4	9.31	2.58	2.73	2.86	2.98	3.21
EPDSE2010-3-ATH	●		3						8.41	3.64	3.82	3.99	4.13	4.39
EPDSE2010-4-ATH	●		4						7.67	4.69	4.91	5.09	5.26	5.54
EPDSE2010-5-ATH	●		5						7.04	5.74	5.99	6.19	6.37	6.76
EPDSE2010-6-ATH	●		6						6.51	6.79	7.06	7.28	7.47	8.08
EPDSE2010-7-ATH	●		7						6.06	7.83	8.12	8.36	8.56	9.41
EPDSE2010-8-ATH	●		8						5.66	8.87	9.18	9.43	9.68	10.74
EPDSE2010-9-ATH	●		9						5.31	9.91	10.24	10.50	10.88	12.07
EPDSE2010-10-ATH	●		10						5.00	10.95	11.30	11.57	12.07	13.39
EPDSE2010-12-ATH	●		12						4.48	13.02	13.40	13.79	14.47	16.05
EPDSE2010-14-ATH	●		14						4.06	15.09	15.49	16.07	16.86	18.70
EPDSE2010-16-ATH	●		16						3.71	17.15	17.58	18.35	19.25	21.36
EPDSE2010-20-ATH	●		20						3.17	21.26	21.89	22.91	24.04	26.66
EPDSE2010-25-ATH	●		25						2.68	26.39	27.33	28.61	30.02	No interference
EPDSE2012-4-ATH	●	1.2	4	1.8	1.15	50	4	4	7.46	4.72	4.93	5.11	5.27	5.55
EPDSE2012-6-ATH	●		6						6.29	6.81	7.08	7.29	7.48	8.11
EPDSE2012-8-ATH	●		8						5.44	8.90	9.20	9.45	9.71	10.77
EPDSE2012-10-ATH	●		10						4.80	10.97	11.31	11.58	12.10	13.42
EPDSE2012-12-ATH	●		12						4.29	13.04	13.41	13.82	14.49	16.08
EPDSE2012-16-ATH	●		16						3.53	17.16	17.59	18.38	19.28	21.39
EPDSE2014-6-ATH	●	1.4	6	2.1	1.34	50	4	4	6.06	6.84	7.09	7.31	7.50	8.15
EPDSE2014-12-ATH	●		12			55			4.08	13.06	13.43	13.84	14.52	16.11
EPDSE2015-4-ATH	●	1.5	4	2.25	1.44	50	4	4	7.11	4.75	4.95	5.13	5.29	5.57
EPDSE2015-6-ATH	●		6						5.94	6.84	7.09	7.31	7.50	8.15
EPDSE2015-8-ATH	●		8						5.10	8.92	9.22	9.46	9.74	10.80
EPDSE2015-10-ATH	●		10						4.47	10.99	11.33	11.59	12.13	13.45
EPDSE2015-12-ATH	●		12						3.97	13.06	13.43	13.84	14.52	16.11
EPDSE2015-14-ATH	●		14						3.58	15.12	15.52	16.12	16.92	18.76
EPDSE2015-16-ATH	●		16			3.25			17.18	17.60	18.40	19.31	21.42	
EPDSE2015-18-ATH	●		18			2.98			19.24	19.76	20.69	21.70	No interference	
EPDSE2015-20-ATH	●		20			2.76			21.29	21.94	22.97	24.10	No interference	
EPDSE2015-25-ATH	●		25			2.31			26.42	27.39	28.67	30.08	No interference	
EPDSE2015-30-ATH	●		30			1.99			31.53	32.83	34.37	No interference	No interference	
EPDSE2015-35-ATH	●		35			1.75			36.64	38.28	40.07	No interference	No interference	
EPDSE2015-40-ATH	●		40			1.56			41.85	43.73	45.78	No interference	No interference	
EPDSE2016-6-ATH	●		1.6			6			2.4	1.54	50	4	4	5.82
EPDSE2016-8-ATH	●	8		4.98	8.92	9.22	9.46	9.74						10.80
EPDSE2018-6-ATH	●	1.8	6	2.7	1.73	50	4	4	5.55	6.86	7.11	7.32	7.51	8.18
EPDSE2018-8-ATH	●		8						4.72	8.94	9.23	9.47	9.76	10.83

● : Stocked items.

Detailed shape below neck

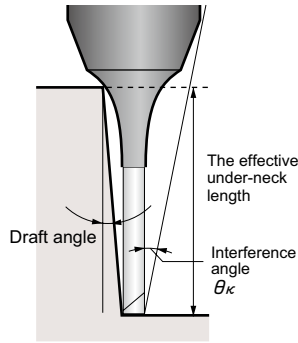
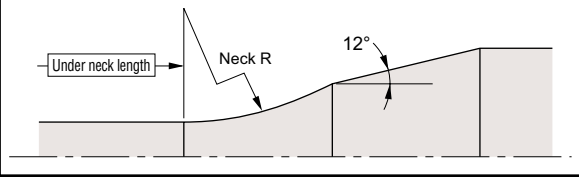

[Note]

The effective under-neck length is different from Epoch Deep Square EPDS. Please recheck the interference region.

EPDSE2000-000-ATH

Item code	Stock ATH	Size(mm)								The effective under-neck length for the various draft angles				
		Tool dia.	Under neck length	Flute length	Neck dia.	Overall length	Shank dia.	Neck R	Interference angle	0.5°	1°	1.5°	2°	3°
		DC	LU	APMX	DN	LF	DCONMS	θκ						
EPDSE2020-4-ATH	●	2	4	3	1.92	50	4	4	6.42	4.80	5.00	5.17	5.32	5.59
EPDSE2020-6-ATH	●		6						5.25	6.88	7.13	7.34	7.52	8.21
EPDSE2020-8-ATH	●		8						4.44	8.96	9.25	9.49	9.79	10.86
EPDSE2020-10-ATH	●		10						3.85	11.03	11.35	11.62	12.19	13.52
EPDSE2020-12-ATH	●		12						3.39	13.10	13.45	13.90	14.58	16.17
EPDSE2020-14-ATH	●		14			3.03			15.16	15.54	16.18	16.97	18.83	
EPDSE2020-16-ATH	●		16			2.75			17.21	17.63	18.46	19.37	No interference	
EPDSE2020-18-ATH	●		18			2.51			19.27	19.81	20.74	21.76	No interference	
EPDSE2020-20-ATH	●		20			2.31			21.32	21.99	23.02	24.15	No interference	
EPDSE2020-25-ATH	●		25			1.92			26.44	27.44	28.72	No interference	No interference	
EPDSE2020-30-ATH	●		30			1.65			31.55	32.88	34.42	No interference	No interference	
EPDSE2020-35-ATH	●		35			1.44			36.69	38.33	No interference	No interference	No interference	
EPDSE2020-40-ATH	●		40			1.28			41.90	43.78	No interference	No interference	No interference	
EPDSE2020-50-ATH	●		50			1.05			52.33	54.67	No interference	No interference	No interference	
EPDSE2025-8-ATH	●		2.5			8			3.75	2.4	50	4	4	3.65
EPDSE2025-12-ATH	●	12		2.73	13.13	13.48	13.95	14.64			No interference			
EPDSE2025-16-ATH	●	16		2.18	17.25	17.68	18.51	19.42			No interference			
EPDSE2025-20-ATH	●	20		1.81	21.35	22.04	23.07	No interference			No interference			
EPDSE2025-30-ATH	●	30		1.28	31.58	32.94	No interference	No interference			No interference			
EPDSE2025-40-ATH	●	40		0.99	41.95	No interference	No interference	No interference			No interference			
EPDSE2025-50-ATH	●	50	0.80	52.38	No interference	No interference	No interference	No interference						
EPDSE2030-8-ATH	●	3	8	4.5	2.88	55	6	4	5.59	9.04	9.31	9.54	9.91	10.99
EPDSE2030-12-ATH	●		12			4.44			13.16	13.50	14.00	14.69	16.30	
EPDSE2030-16-ATH	●		16			3.68			17.28	17.73	18.57	19.48	21.61	
EPDSE2030-20-ATH	●		20			3.15			21.38	22.09	23.13	24.26	26.91	
EPDSE2030-25-ATH	●		25			2.66			26.49	27.54	28.83	30.25	No interference	
EPDSE2030-30-ATH	●		30			2.31			31.60	32.99	34.53	36.23	No interference	
EPDSE2030-40-ATH	●		40			1.82			42.00	43.88	45.94	No interference	No interference	
EPDSE2030-50-ATH	●	50	1.50	52.43	54.78	No interference	No interference	No interference						
EPDSE2040-12-ATH	●	4	12	6	3.85	60	6	4	3.36	13.21	13.54	14.08	14.78	16.39
EPDSE2040-16-ATH	●		16			2.72			17.32	17.81	18.65	19.56	No interference	
EPDSE2040-20-ATH	●		20			2.29			21.42	22.17	23.21	24.35	No interference	
EPDSE2040-25-ATH	●		25			1.91			26.53	27.62	28.91	No interference	No interference	
EPDSE2040-30-ATH	●		30			1.64			31.65	33.06	34.61	No interference	No interference	
EPDSE2040-35-ATH	●		35			1.44			36.86	38.51	No interference	No interference	No interference	
EPDSE2040-40-ATH	●		40			1.28			42.08	43.96	No interference	No interference	No interference	
EPDSE2040-50-ATH	●		50			1.05			52.50	54.85	No interference	No interference	No interference	
EPDSE2050-20-ATH	●	5	20	7.5	4.85	70	6	4	1.27	21.42	22.17	No interference	No interference	No interference
EPDSE2050-25-ATH	●		25			1.04			26.53	27.62	No interference	No interference	No interference	
EPDSE2050-30-ATH	●		30			0.88			31.65	No interference	No interference	No interference	No interference	
EPDSE2050-40-ATH	●		40			0.68			42.08	No interference	No interference	No interference	No interference	
EPDSE2050-50-ATH	●		50			0.55			52.50	No interference	No interference	No interference	No interference	
EPDSE2060-20-ATH	●	6	20	9	5.85	70	6	-	0	No interference	No interference	No interference	No interference	No interference
EPDSE2060-30-ATH	●		30			0			No interference	No interference	No interference	No interference	No interference	
EPDSE2060-40-ATH	●		40			0			No interference	No interference	No interference	No interference	No interference	
EPDSE2060-50-ATH	●		50			0			No interference	No interference	No interference	No interference	No interference	

● : Stocked items.

Features

Dimensions
Ball PN Coating

Dimensions
Ball ATH Coating

Cutting condition
Ball High efficiency

Cutting condition
Ball High accuracy

Dimensions
Square PN Coating

Dimensions
Square ATH Coating

Cutting condition
Square High efficiency

Cutting condition
Square High accuracy

Technical Data

Recommended Cutting Conditions

High efficiency cutting condition

High accuracy cutting condition

Please refer to P.25 about high accuracy cutting conditions

Epoch Deep Square Evolution **EPDSE-PN** **EPDSE-ATH**

Recommended range			PN series											
			ATH series											
Work material			1		2		3		4		5		6	
			Coppers		Carbon steels, Alloy steels (180~250HB)		Stainless steels, Tool steels (25~35HRC)		Pre-hardened steels (35~45HRC)		Hardened steels (45~55HRC)		Hardened steels (55~65HRC)	
Ratio to standard depth of cut			120%		100%		90%		70%		50%		45%	
Tool dia. DC (mm)	Under neck length LU (mm)	ap (mm)	Revolution n min ⁻¹	Feed rate vf mm/min	Revolution n min ⁻¹	Feed rate vf mm/min	Revolution n min ⁻¹	Feed rate vf mm/min	Revolution n min ⁻¹	Feed rate vf mm/min	Revolution n min ⁻¹	Feed rate vf mm/min	Revolution n min ⁻¹	Feed rate vf mm/min
0.1	0.3	0.006	50,000	500	50,000	500	50,000	475	48,600	348	42,750	255	40,050	208
	0.5	0.004	50,000	500	50,000	500	50,000	475	48,600	348	42,750	255	40,050	208
	1	0.003	50,000	455	50,000	455	48,600	430	43,700	315	38,500	232	36,050	187
0.2	0.5	0.02	50,000	708	45,000	638	40,500	574	38,250	403	33,750	301	31,500	242
	1	0.014	50,000	708	45,000	638	40,500	574	38,250	403	33,750	301	31,500	242
	1.5	0.008	48,600	630	40,500	525	36,450	472	34,425	362	30,375	271	28,350	218
	2	0.005	43,200	504	36,000	420	32,400	378	30,600	286	27,000	214	25,200	172
0.3	3	0.003	43,200	454	36,000	378	32,400	340	30,600	257	27,000	193	25,200	155
	1	0.021	48,000	680	40,000	567	36,000	510	34,000	358	30,000	267	28,000	216
	1.5	0.021	48,000	680	40,000	567	36,000	510	34,000	358	30,000	267	28,000	216
	2	0.012	43,200	560	36,000	467	32,400	420	30,600	322	27,000	241	25,200	194
0.4	2.5	0.01	43,200	560	36,000	467	32,400	420	30,600	322	27,000	241	25,200	194
	3	0.008	43,200	560	36,000	467	32,400	420	30,600	322	27,000	241	25,200	194
	1	0.04	38,400	847	32,000	706	28,800	635	27,200	446	24,000	333	22,400	268
	1.5	0.028	38,400	847	32,000	706	28,800	635	27,200	446	24,000	333	22,400	268
	2	0.028	38,400	847	32,000	706	28,800	635	27,200	446	24,000	333	22,400	268
	2.5	0.022	34,560	697	28,800	581	25,920	523	24,480	401	21,600	299	20,160	241
	3	0.016	34,560	697	28,800	581	25,920	523	24,480	401	21,600	299	20,160	241
	3.5	0.012	34,560	697	28,800	581	25,920	523	24,480	401	21,600	299	20,160	241
	4	0.01	34,560	697	28,800	581	25,920	523	24,480	401	21,600	299	20,160	241
	5	0.01	30,720	542	25,600	452	23,040	406	21,760	260	19,200	230	17,920	181
0.5	6	0.006	30,720	542	25,600	452	23,040	406	21,760	260	19,200	230	17,920	181
	8	0.003	26,880	413	22,400	344	20,160	310	19,040	200	16,800	172	15,680	131
	10	0.002	23,040	304	19,200	253	17,280	228	16,320	147	14,400	127	13,440	96
	1	0.05	38,400	847	32,000	706	28,800	635	27,200	535	24,000	333	22,400	268
	1.5	0.05	38,400	847	32,000	706	28,800	635	27,200	535	24,000	333	22,400	268
	2	0.035	38,400	847	32,000	706	28,800	635	27,200	535	24,000	333	22,400	268
	2.5	0.03	34,560	697	28,800	581	25,920	523	24,480	441	21,600	299	20,160	241
	3	0.02	34,560	697	28,800	581	25,920	523	24,480	441	21,600	299	20,160	241
	4	0.02	34,560	697	28,800	581	25,920	523	24,480	401	21,600	299	20,160	241
	5	0.013	34,560	697	28,800	581	25,920	523	24,480	401	21,600	299	20,160	241
0.6	6	0.013	30,720	542	25,600	452	23,040	406	21,760	260	19,200	230	17,920	181
	8	0.008	30,720	464	25,600	387	23,040	348	21,760	247	19,200	194	17,920	147
	10	0.004	26,880	360	22,400	300	20,160	270	19,040	174	16,800	150	15,680	114
	2	0.042	38,400	1,210	32,000	1,008	28,800	907	27,200	636	24,000	475	22,400	383
	3	0.035	34,560	995	28,800	829	25,920	746	24,480	573	21,600	428	20,160	345
	4	0.024	34,560	995	28,800	829	25,920	746	24,480	573	21,600	428	20,160	345
	5	0.02	34,560	995	28,800	829	25,920	746	24,480	573	21,600	428	20,160	345
	6	0.015	34,560	995	28,800	829	25,920	746	24,480	573	21,600	428	20,160	345
	7	0.015	30,720	859	25,600	716	23,040	644	21,760	494	19,200	369	17,920	298
	8	0.015	30,720	774	25,600	645	23,040	581	21,760	372	19,200	328	17,920	258
0.7	9	0.012	30,720	774	25,600	645	23,040	581	21,760	372	19,200	328	17,920	258
	10	0.009	30,720	774	25,600	645	23,040	581	21,760	372	19,200	328	17,920	258
	2	0.07	38,400	1,210	32,000	1,008	28,800	907	27,200	636	24,000	475	22,400	384
	4	0.049	34,560	995	28,800	829	25,920	746	24,480	573	21,600	428	20,160	345
	6	0.018	34,560	995	28,800	829	25,920	746	24,480	573	21,600	428	20,160	345
	8	0.018	30,720	774	25,600	645	23,040	581	21,760	372	19,200	328	17,920	258
	10	0.018	30,720	774	25,600	645	23,040	581	21,760	372	19,200	328	17,920	258

[Note] Please refer to P.24

Recommended range			PN series											
			ATH series											
Work material			1		2		3		4		5		6	
			Coppers		Carbon steels, Alloy steels (180~250HB)		Stainless steels, Tool steels (25~35HRC)		Pre-hardened steels (35~45HRC)		Hardened steels (45~55HRC)		Hardened steels (55~65HRC)	
Ratio to standard depth of cut			120%		100%		90%		70%		50%		45%	
Tool dia. DC (mm)	Under neck length LU (mm)	a_p (mm)	Revolution n min ⁻¹	Feed rate vf mm/min	Revolution n min ⁻¹	Feed rate vf mm/min	Revolution n min ⁻¹	Feed rate vf mm/min	Revolution n min ⁻¹	Feed rate vf mm/min	Revolution n min ⁻¹	Feed rate vf mm/min	Revolution n min ⁻¹	Feed rate vf mm/min
0.8	2	0.08	38,400	1,210	32,000	1,008	28,800	907	27,200	780	24,000	688	22,400	422
	4	0.056	38,400	1,210	32,000	1,008	28,800	907	27,200	780	24,000	688	22,400	422
	6	0.032	34,560	995	28,800	829	25,920	746	24,480	678	24,000	665	20,160	379
	8	0.02	34,560	995	28,800	829	25,920	746	24,480	573	21,600	428	20,160	345
	10	0.02	30,720	774	25,600	645	23,040	581	21,760	372	19,200	328	17,920	258
	12	0.012	30,720	774	25,600	645	23,040	581	21,760	372	19,200	328	17,920	258
0.9	2	0.09	38,400	1,326	32,000	1,205	28,800	1,085	27,200	833	24,000	674	22,400	502
	4	0.063	38,400	1,326	32,000	1,205	28,800	1,085	27,200	833	24,000	674	22,400	502
	6	0.036	34,560	1,094	28,800	994	25,920	895	24,480	687	21,600	556	20,160	414
	8	0.023	34,560	1,094	28,800	911	25,920	820	24,480	630	21,600	513	20,160	379
	10	0.023	30,720	774	25,600	645	23,040	581	21,760	372	19,200	328	17,920	258
	12	0.023	30,720	774	25,600	645	23,040	581	21,760	372	19,200	328	17,920	258
1	2	0.1	34,560	1,628	28,800	1,356	25,920	1,220	24,480	1,150	22,930	1,008	20,160	846
	3	0.085	34,560	1,628	28,800	1,356	25,920	1,220	24,480	1,150	22,930	1,008	20,160	846
	4	0.07	34,560	1,628	28,800	1,356	25,920	1,220	24,480	1,077	22,930	963	20,160	766
	5	0.055	34,560	1,628	28,800	1,356	25,920	1,220	24,480	1,028	22,930	871	20,160	685
	6	0.04	31,104	1,344	25,920	1,120	23,328	1,008	22,032	903	20,700	745	18,144	465
	7	0.04	31,104	1,344	25,920	1,120	23,328	1,008	22,032	837	20,700	703	18,144	465
	8	0.04	31,104	1,344	25,920	1,120	23,328	1,008	22,032	837	20,700	622	18,144	465
	9	0.033	31,104	1,344	25,920	1,120	23,328	1,008	22,032	773	19,440	577	18,144	465
	10	0.025	31,104	1,344	25,920	1,120	23,328	1,008	22,032	773	19,440	577	18,144	465
	12	0.025	27,648	1,045	23,040	871	20,736	784	19,584	502	17,280	443	16,128	348
	14	0.025	27,648	1,045	23,040	871	20,736	784	19,584	502	17,280	443	16,128	348
	16	0.015	27,648	896	23,040	746	20,736	672	19,584	476	17,280	373	16,128	283
	20	0.01	24,828	732	20,690	610	22,345	549	17,587	348	15,518	305	14,483	226
	25	0.005	21,000	569	17,500	474	18,900	427	14,875	270	13,125	237	12,250	175
1.2	4	0.09	30,720	1,452	25,600	1,210	23,040	1,089	21,760	870	19,200	570	17,920	460
	6	0.084	30,720	1,452	25,600	1,210	23,040	1,089	21,760	870	19,200	570	17,920	460
	8	0.048	27,648	1,194	23,040	995	20,736	896	19,584	783	17,280	513	16,128	414
	10	0.03	27,648	1,194	23,040	995	20,736	896	19,584	744	17,280	513	16,128	414
	12	0.03	27,648	1,194	23,040	995	20,736	896	19,584	687	17,280	513	16,128	414
	16	0.02	24,576	1,061	20,480	884	18,432	796	17,408	611	15,360	456	14,336	368
1.4	6	0.1	26,880	1,270	22,400	1,058	20,160	953	19,040	668	16,800	499	15,680	403
	12	0.035	24,192	1,045	20,160	871	18,144	784	17,136	601	15,120	449	14,112	362
1.5	4	0.11	26,880	1,397	22,400	1,163	20,160	1,048	19,040	801	16,800	648	15,680	482
	6	0.11	26,880	1,397	22,400	1,163	20,160	1,048	19,040	801	16,800	623	15,680	482
	8	0.08	24,192	1,149	20,160	958	18,144	940	17,136	721	15,120	538	14,112	416
	10	0.06	24,192	1,149	20,160	871	18,144	862	17,136	721	15,120	538	14,112	416
	12	0.06	24,192	1,045	20,160	871	18,144	784	17,136	721	15,120	449	14,112	362
	14	0.038	24,192	1,045	20,160	871	18,144	784	17,136	721	15,120	449	14,112	362
	16	0.038	21,504	813	17,920	677	16,128	610	15,232	391	13,440	345	12,544	271
	18	0.038	21,504	813	17,920	677	16,128	610	15,232	391	13,440	345	12,544	271
	20	0.038	21,504	813	17,920	677	16,128	610	15,232	391	13,440	345	12,544	271
	25	0.023	16,128	523	13,440	435	12,096	392	11,424	278	10,080	218	9,408	165
	30	0.015	13,440	355	11,200	296	12,096	266	9,520	178	8,400	139	7,840	112
	35	0.01	13,440	355	11,200	296	12,096	266	9,520	178	8,400	139	7,840	112
40	0.005	10,752	190	8,960	158	8,064	142	7,616	95	6,720	74	6,272	60	
1.6	6	0.11	24,960	1,310	20,800	1,201	18,720	1,130	17,680	759	15,600	566	14,560	456
	8	0.11	24,960	1,310	20,800	1,201	18,720	983	17,680	690	15,600	566	14,560	456
1.8	6	0.13	24,960	1,310	20,800	1,201	18,720	1,179	17,680	759	15,600	618	14,560	498
	8	0.13	24,960	1,310	20,800	1,201	18,720	1,081	17,680	690	15,600	618	14,560	498

[Note] Please refer to P.24

Features

Dimensions
Ball PN Coating

Dimensions
Ball ATH Coating

Cutting condition
Ball High efficiency

Cutting condition
Ball High accuracy

Dimensions
Square PN Coating

Dimensions
Square ATH Coating

Cutting condition
Square High efficiency

Cutting condition
Square High accuracy

Technical Data

Recommended Cutting Conditions

High efficiency cutting condition

High accuracy cutting condition

Please refer to P.25 about high accuracy cutting conditions

Epoch Deep Square Evolution **EPDSE-PN** **EPDSE-ATH**

Recommended range			PN series											
			ATH series											
Work material			1	2		3		4		5		6		
			Coppers	Carbon steels, Alloy steels (180~250HB)		Stainless steels, Tool steels (25~35HRC)		Pre-hardened steels (35~45HRC)		Hardened steels (45~55HRC)		Hardened steels (55~65HRC)		
Ratio to standard depth of cut			120%	100%		90%		70%		50%		45%		
Tool dia. DC (mm)	Under neck length LU (mm)	ap (mm)	Revolution n min ⁻¹	Feed rate vf mm/min	Revolution n min ⁻¹	Feed rate vf mm/min	Revolution n min ⁻¹	Feed rate vf mm/min	Revolution n min ⁻¹	Feed rate vf mm/min	Revolution n min ⁻¹	Feed rate vf mm/min	Revolution n min ⁻¹	Feed rate vf mm/min
			2	4	0.2	20,160	1,397	16,800	1,174	15,120	1,048	14,280	734	12,600
	6	0.2	20,160	1,397	16,800	1,174	15,120	1,048	14,280	734	12,600	548	11,760	443
	8	0.14	20,160	1,397	16,800	1,174	15,120	1,048	14,280	734	12,600	548	11,760	443
	10	0.14	20,160	1,397	16,800	1,174	15,120	1,048	14,280	734	12,600	548	11,760	443
	12	0.1	18,144	1,149	15,120	958	13,608	862	12,852	661	11,340	493	10,584	398
	14	0.08	18,144	1,149	15,120	958	13,608	862	12,852	661	11,340	493	10,584	362
	16	0.08	18,144	1,045	15,120	914	13,608	862	12,852	601	11,340	449	10,584	362
	18	0.05	18,144	1,045	15,120	914	13,608	862	12,852	601	11,340	449	10,584	362
	20	0.05	18,144	1,045	15,120	871	13,608	784	12,852	601	11,340	449	10,584	362
	25	0.05	16,128	813	13,440	677	12,096	610	11,424	391	10,080	345	9,408	271
	30	0.03	16,128	813	13,440	677	12,096	610	11,424	391	10,080	345	9,408	271
	35	0.02	14,112	583	11,760	486	10,584	437	9,996	282	8,820	228	8,232	185
	40	0.01	14,112	583	11,760	486	10,584	437	9,996	282	8,820	228	8,232	185
	50	0.005	12,096	355	10,080	296	9,072	266	8,568	172	7,560	139	7,056	112
2.5	8	0.18	17,280	1,497	14,400	1,247	12,960	1,123	12,240	787	10,800	642	10,080	474
	12	0.18	17,280	1,260	14,400	1,247	12,960	1,123	12,240	716	10,800	588	10,080	431
	16	0.1	15,552	1,120	12,960	1,073	11,664	966	11,016	644	9,720	529	9,072	388
	20	0.1	15,552	1,120	12,960	933	11,664	840	11,016	644	9,720	529	9,072	388
	30	0.06	13,824	870	11,520	725	10,368	653	9,792	435	8,640	341	8,064	276
	40	0.03	12,096	625	10,080	521	9,072	469	8,568	313	7,560	245	7,056	198
	50	0.01	12,096	625	10,080	521	9,072	469	8,568	313	7,560	245	7,056	198
3	8	0.3	15,360	1,331	12,800	1,108	11,520	997	10,880	699	10,600	570	8,960	422
	12	0.21	15,360	1,331	12,800	1,108	11,520	997	10,880	699	10,600	570	8,960	422
	16	0.15	13,824	1,144	11,520	994	10,368	820	9,792	630	9,450	513	8,064	379
	20	0.12	13,824	995	11,520	911	10,368	820	9,792	630	9,450	513	8,064	379
	25	0.08	13,824	995	11,520	911	10,368	820	9,792	630	9,450	513	8,064	379
	30	0.08	13,824	995	11,520	829	10,368	746	9,792	630	9,450	513	8,064	347
	40	0.05	12,288	884	10,240	737	9,216	663	8,704	509	7,680	380	7,168	307
	50	0.02	10,752	556	8,960	463	8,064	417	7,616	278	6,720	218	6,272	176
4	12	0.4	11,500	2,300	9,400	1,880	8,460	1,524	7,990	1,358	7,050	902	6,580	728
	16	0.28	11,500	2,300	9,400	1,880	8,460	1,524	7,990	1,358	7,050	902	6,580	728
	20	0.28	10,350	2,070	8,460	1,692	7,614	1,371	7,191	1,222	6,345	812	5,922	655
	25	0.16	10,350	1,863	8,460	1,524	7,614	1,233	7,191	1,100	6,345	812	5,922	655
	30	0.16	10,350	1,863	8,460	1,524	7,614	1,233	7,191	1,100	6,345	812	5,922	655
	35	0.1	9,137	1,645	7,614	1,371	6,853	1,110	6,472	990	5,711	731	5,330	589
	40	0.1	9,137	1,645	7,614	1,371	6,853	1,110	6,472	990	5,711	731	5,330	589
	50	0.06	7,896	1,128	6,580	940	5,922	846	5,593	658	4,935	442	4,606	357
5	20	0.3	9,014	1,802	7,512	1,652	6,761	1,487	6,385	1,051	5,634	706	5,258	571
	25	0.3	8,112	1,621	6,760	1,351	6,084	1,216	5,746	946	5,070	635	4,732	513
	30	0.2	8,112	1,461	6,760	1,217	6,084	1,094	5,746	851	5,070	573	4,732	462
	40	0.15	7,301	1,315	6,084	1,096	5,476	986	5,171	767	4,563	515	4,259	416
	50	0.1	7,301	1,315	6,084	1,096	5,476	986	5,171	767	4,563	515	4,259	416
6	20	0.5	7,418	1,629	6,182	1,481	5,564	1,333	5,255	1,036	4,637	766	4,327	562
	30	0.4	6,744	1,480	5,620	1,346	5,058	1,212	4,777	942	4,215	696	3,934	511
	40	0.3	6,744	1,332	5,620	1,109	5,058	998	4,777	847	4,215	625	3,934	459
	50	0.2	6,000	1,090	5,000	986	4,500	887	4,250	690	3,750	515	3,500	379

*ap is shown as the criteria for Group 2 workpieces. For other groups, adjust the cutting depth according to the cutting depth factors in the above table.

- [Note]**
- ① PN coating is less electro conductive. Therefore, electric transmitted measuring systems may not work.
 - ② Use the appropriate coolant for the work material and machining shape.
 - ③ These Recommended Cutting Conditions indicate only the rule of a thumb for the cutting conditions. In actual machining, the condition should be adjusted according to the machining shape, purpose and the machine type.
 - ④ If the rpm of the machine is low, lower the feed rate also to put the rpm and feed rate in the same ratio.

High efficiency
cutting condition

**High accuracy
cutting condition**

Please refer to P.22
about high efficiency cutting conditions

Epoch Deep Square Evolution **EPDSE-PN** **EPDSE-ATH**

Recommended range			PN series											
			ATH series											
Work material			1	2		3		4		5		6		
			Coppers	Carbon steels, Alloy steels (180~250HB)		Stainless steels, Tool steels (25~35HRC)		Pre-hardened steels (35~45HRC)		Hardened steels (45~55HRC)		Hardened steels (55~65HRC)		
Ratio to standard depth of cut			120%		100%		90%		70%		50%		45%	
Tool dia. DC (mm)	Under neck length LU (mm)	a_p (mm)	Revolution n min ⁻¹	Feed rate v_f mm/min	Revolution n min ⁻¹	Feed rate v_f mm/min	Revolution n min ⁻¹	Feed rate v_f mm/min	Revolution n min ⁻¹	Feed rate v_f mm/min	Revolution n min ⁻¹	Feed rate v_f mm/min	Revolution n min ⁻¹	Feed rate v_f mm/min
0.1	0.3	0.006	50,000	350	50,000	350	50,000	332	48,600	242	42,750	178	40,050	144
	0.5	0.004	50,000	350	50,000	350	50,000	332	48,600	242	42,750	178	40,050	144
	1	0.003	50,000	318	50,000	318	48,600	301	43,700	220	38,500	162	36,050	129
0.2	0.5	0.015	50,000	495	45,000	446	40,500	401	38,250	282	33,750	210	31,500	169
	1	0.011	50,000	495	45,000	446	40,500	401	38,250	282	33,750	210	31,500	169
	1.5	0.006	48,600	441	40,500	367	36,450	330	34,425	253	30,375	189	28,350	152
	2	0.004	43,200	352	36,000	294	32,400	264	30,600	200	27,000	165	25,200	147
0.3	3	0.002	43,200	317	36,000	264	32,400	238	30,600	179	27,000	165	25,200	133
	1	0.021	48,000	544	40,000	453	36,000	408	34,000	286	30,000	240	28,000	193
	1.5	0.021	48,000	544	40,000	453	36,000	408	34,000	286	30,000	240	28,000	193
	2	0.012	43,200	448	36,000	373	32,400	336	30,600	257	27,000	192	25,200	155
	2.5	0.01	43,200	448	36,000	373	32,400	336	30,600	257	27,000	192	25,200	155
0.4	3	0.008	43,200	448	36,000	373	32,400	336	30,600	257	27,000	180	25,200	145
	1	0.04	38,400	762	32,000	635	28,800	571	27,200	401	24,000	297	22,400	241
	1.5	0.028	38,400	762	32,000	635	28,800	571	27,200	401	24,000	297	22,400	241
	2	0.028	38,400	762	32,000	635	28,800	571	27,200	401	24,000	297	22,400	241
	2.5	0.022	34,560	557	28,800	464	25,920	418	24,480	320	21,600	239	20,160	192
	3	0.016	34,560	557	28,800	464	25,920	418	24,480	320	21,600	239	20,160	192
	3.5	0.012	34,560	557	28,800	464	25,920	418	24,480	320	21,600	239	20,160	192
	4	0.01	34,560	557	28,800	464	25,920	418	24,480	320	21,600	239	20,160	192
	5	0.01	30,720	406	25,600	316	23,040	284	21,760	208	19,200	184	17,920	144
	6	0.006	30,720	406	25,600	316	23,040	284	21,760	208	19,200	184	17,920	144
0.5	8	0.003	26,880	289	22,400	240	20,160	217	19,040	160	16,800	141	15,680	128
	10	0.002	23,040	212	19,200	177	17,280	159	16,320	117	14,400	103	13,440	94
	1	0.05	38,400	762	32,000	635	28,800	571	27,200	446	24,000	299	22,400	241
	1.5	0.05	38,400	762	32,000	635	28,800	571	27,200	446	24,000	299	22,400	241
	2	0.035	38,400	762	32,000	635	28,800	571	27,200	446	24,000	299	22,400	241
	2.5	0.03	34,560	557	28,800	464	25,920	418	24,480	354	21,600	239	20,160	192
	3	0.02	34,560	557	28,800	464	25,920	418	24,480	354	21,600	239	20,160	192
	4	0.02	34,560	557	28,800	464	25,920	418	24,480	320	21,600	239	20,160	192
	5	0.013	34,560	557	28,800	464	25,920	418	24,480	320	21,600	239	20,160	192
	6	0.013	30,720	433	25,600	361	23,040	324	21,760	208	19,200	184	17,920	144
0.6	8	0.008	30,720	371	25,600	309	23,040	278	21,760	172	19,200	155	17,920	117
	10	0.004	26,880	288	22,400	240	20,160	216	19,040	121	16,800	105	15,680	79
	2	0.042	38,400	1,089	32,000	907	28,800	816	27,200	572	24,000	427	22,400	344
	3	0.035	34,560	895	28,800	746	25,920	671	24,480	515	21,600	385	20,160	310
	4	0.024	34,560	895	28,800	746	25,920	671	24,480	515	21,600	385	20,160	310
	5	0.02	34,560	796	28,800	663	25,920	596	24,480	458	21,600	342	20,160	276
	6	0.015	34,560	796	28,800	663	25,920	596	24,480	458	21,600	342	20,160	276
	7	0.015	30,720	687	25,600	572	23,040	515	21,760	395	19,200	295	17,920	238
	8	0.015	30,720	595	25,600	516	23,040	464	21,760	297	19,200	262	17,920	206
	9	0.012	30,720	595	25,600	516	23,040	464	21,760	297	19,200	262	17,920	206
0.7	10	0.009	30,720	595	25,600	516	23,040	464	21,760	297	19,200	262	17,920	206
	2	0.07	38,400	1,089	32,000	907	28,800	816	27,200	572	24,000	427	22,400	344
	4	0.049	34,560	796	28,800	663	25,920	596	24,480	458	21,600	342	20,160	276
	6	0.018	34,560	796	28,800	663	25,920	596	24,480	458	21,600	342	20,160	276
	8	0.018	30,720	541	25,600	451	23,040	406	21,760	260	19,200	229	17,920	180
10	0.018	30,720	541	25,600	451	23,040	406	21,760	260	19,200	229	17,920	180	

[Note] Please refer to P.27

Features
Dimensions
Ball/PN Coating
Dimensions
Ball/ATH Coating
Cutting condition
Ball/High efficiency
Cutting condition
Ball/High accuracy
Dimensions
Square/PN Coating
Dimensions
Square/ATH Coating
Cutting condition
Square/High efficiency
Cutting condition
Square/High accuracy
Technical Data

Recommended Cutting Conditions

High efficiency cutting condition

High accuracy cutting condition

Please refer to P.22 about high efficiency cutting conditions

Epoch Deep Square Evolution **EPDSE-PN** **EPDSE-ATH**

Recommended range			PN series											
			ATH series											
Work material			1	2	3	4	5	6						
			Coppers	Carbon steels, Alloy steels (180~250HB)	Stainless steels, Tool steels (25~35HRC)	Pre-hardened steels (35~45HRC)	Hardened steels (45~55HRC)	Hardened steels (55~65HRC)						
Ratio to standard depth of cut			120%	100%	90%	70%	50%	45%						
Tool dia. DC (mm)	Under neck length LU (mm)	ap (mm)	Revolution n min ⁻¹	Feed rate vf mm/min	Revolution n min ⁻¹	Feed rate vf mm/min	Revolution n min ⁻¹	Feed rate vf mm/min	Revolution n min ⁻¹	Feed rate vf mm/min	Revolution n min ⁻¹	Feed rate vf mm/min	Revolution n min ⁻¹	Feed rate vf mm/min
			0.8	2	0.08	38,400	1,089	32,000	907	28,800	816	27,200	636	24,000
	4	0.056	38,400	1,089	32,000	907	28,800	816	27,200	636	24,000	475	22,400	383
	6	0.032	34,560	796	28,800	663	25,920	596	24,480	573	21,600	428	20,160	345
	8	0.02	34,560	796	28,800	663	25,920	596	24,480	458	21,600	342	20,160	276
	10	0.02	30,720	541	25,600	451	23,040	406	21,760	260	19,200	229	17,920	180
	12	0.012	30,720	541	25,600	451	23,040	406	21,760	260	19,200	229	17,920	180
0.9	2	0.09	38,400	1,206	32,000	1,005	28,800	904	27,200	695	24,000	519	22,400	418
	4	0.063	38,400	1,206	32,000	1,005	28,800	904	27,200	695	24,000	519	22,400	418
	6	0.036	34,560	995	28,800	829	25,920	746	24,480	573	21,600	428	20,160	345
	8	0.023	34,560	995	28,800	746	25,920	746	24,480	573	21,600	428	20,160	345
	10	0.023	30,720	619	25,600	516	23,040	464	21,760	297	19,200	262	17,920	206
	12	0.023	30,720	541	25,600	451	23,040	414	21,760	297	19,200	262	17,920	206
1	2	0.09	34,560	1,465	28,800	1,220	25,920	1,098	24,480	936	21,600	699	20,160	563
	3	0.07	34,560	1,465	28,800	1,220	25,920	1,098	24,480	936	21,600	699	20,160	563
	4	0.065	34,560	1,465	28,800	1,220	25,920	1,098	24,480	936	21,600	699	20,160	563
	5	0.05	34,560	1,465	28,800	1,220	25,920	1,098	24,480	936	21,600	699	20,160	563
	6	0.035	31,104	1,276	25,920	1,008	23,328	907	22,032	773	19,440	577	18,144	418
	7	0.035	31,104	1,276	25,920	1,008	23,328	907	22,032	773	19,440	577	18,144	418
	8	0.035	31,104	1,209	25,920	1,008	23,328	907	22,032	773	19,440	577	18,144	418
	9	0.03	31,104	1,209	25,920	1,008	23,328	907	22,032	695	19,440	461	18,144	372
	10	0.022	31,104	1,209	25,920	896	23,328	816	22,032	695	19,440	461	18,144	372
	12	0.022	27,648	836	23,040	696	20,736	627	19,584	401	17,280	354	16,128	278
	14	0.022	27,648	836	23,040	696	20,736	627	19,584	401	17,280	354	16,128	278
	16	0.012	27,648	716	23,040	596	20,736	537	19,584	380	17,280	298	16,128	226
	20	0.008	24,828	586	20,690	488	18,621	439	17,587	278	15,518	213	14,483	158
	25	0.005	21,000	455	17,500	379	15,750	341	14,875	216	13,125	165	12,250	122
1.2	4	0.09	30,720	1,306	25,600	1,089	23,040	980	21,760	760	19,200	513	17,920	414
	6	0.084	30,720	1,306	25,600	1,089	23,040	980	21,760	760	19,200	513	17,920	414
	8	0.048	27,648	1,074	23,040	895	20,736	806	19,584	684	17,280	461	16,128	372
	10	0.03	27,648	1,074	23,040	895	20,736	806	19,584	684	17,280	461	16,128	372
	12	0.03	27,648	955	23,040	716	20,736	642	19,584	549	17,280	410	16,128	331
	16	0.02	24,576	848	20,480	707	18,432	557	17,408	488	15,360	364	14,336	294
1.4	6	0.1	26,880	1,143	22,400	952	20,160	857	19,040	601	16,800	449	15,680	361
	12	0.035	24,192	940	20,160	783	18,144	705	17,136	540	15,120	404	14,112	325
1.5	4	0.11	26,880	1,270	22,400	1,058	20,160	953	19,040	668	16,800	499	15,680	402
	6	0.11	26,880	1,143	22,400	952	20,160	866	19,040	668	16,800	499	15,680	402
	8	0.06	24,192	1,045	20,160	871	18,144	784	17,136	601	15,120	449	14,112	362
	10	0.06	24,192	1,045	20,160	783	18,144	705	17,136	601	15,120	449	14,112	362
	12	0.06	24,192	940	20,160	783	18,144	705	17,136	601	15,120	404	14,112	325
	14	0.038	24,192	940	20,160	783	18,144	705	17,136	601	15,120	404	14,112	325
	16	0.038	21,504	731	17,920	609	16,128	549	15,232	351	13,440	310	12,544	243
	18	0.038	21,504	731	17,920	609	16,128	549	15,232	351	13,440	310	12,544	243
	20	0.038	21,504	731	17,920	609	16,128	488	15,232	312	13,440	276	12,544	216
	25	0.023	16,128	470	13,440	391	12,096	313	11,424	222	10,080	174	9,408	132
	30	0.015	13,440	319	11,200	266	12,096	212	9,520	149	8,400	111	7,840	89
	35	0.01	13,440	284	11,200	236	12,096	186	9,520	149	8,400	111	7,840	89
	40	0.005	10,752	152	8,960	126	8,064	113	7,616	76	6,720	59	6,272	48
1.6	6	0.11	24,960	1,179	20,800	977	18,720	884	17,680	690	15,600	515	14,560	415
	8	0.11	24,960	1,179	20,800	977	18,720	884	17,680	621	15,600	515	14,560	415
1.8	6	0.13	24,960	1,179	20,800	997	18,720	884	17,680	690	15,600	515	14,560	415
	8	0.13	24,960	1,179	20,800	997	18,720	884	17,680	621	15,600	515	14,560	415

[Note] Please refer to P.27

Recommended range		PN series												
		ATH series												
Work material			1		2		3		4		5		6	
			Coppers		Carbon steels, Alloy steels (180~250HB)		Stainless steels, Tool steels (25~35HRC)		Pre-hardened steels (35~45HRC)		Hardened steels (45~55HRC)		Hardened steels (55~65HRC)	
Ratio to standard depth of cut			120%		100%		90%		70%		50%		45%	
Tool dia. DC (mm)	Under neck length LU (mm)	a_p (mm)	Revolution n min ⁻¹	Feed rate v_f mm/min	Revolution n min ⁻¹	Feed rate v_f mm/min	Revolution n min ⁻¹	Feed rate v_f mm/min	Revolution n min ⁻¹	Feed rate v_f mm/min	Revolution n min ⁻¹	Feed rate v_f mm/min	Revolution n min ⁻¹	Feed rate v_f mm/min
2	4	0.2	20,160	1,270	16,800	952	15,120	861	14,280	655	12,600	499	11,760	402
	6	0.2	20,160	1,270	16,800	952	15,120	861	14,280	655	12,600	499	11,760	402
	8	0.14	20,160	1,270	16,800	952	15,120	861	14,280	655	12,600	499	11,760	402
	10	0.14	20,160	1,270	16,800	952	15,120	861	14,280	655	12,600	499	11,760	402
	12	0.08	18,144	1,045	15,120	871	13,608	784	12,852	590	11,340	449	10,584	362
	14	0.08	18,144	1,045	15,120	871	13,608	784	12,852	590	11,340	449	10,584	325
	16	0.08	18,144	940	15,120	783	13,608	707	12,852	540	11,340	426	10,584	325
	18	0.05	18,144	940	15,120	783	13,608	707	12,852	540	11,340	404	10,584	289
	20	0.05	18,144	888	15,120	696	13,608	627	12,852	480	11,340	359	10,584	289
	25	0.05	16,128	731	13,440	609	12,096	549	11,424	312	10,080	310	9,408	232
	30	0.03	16,128	650	13,440	541	12,096	488	11,424	273	10,080	276	9,408	216
	35	0.02	14,112	466	11,760	388	10,584	349	9,996	225	8,820	182	8,232	148
40	0.01	14,112	408	11,760	340	10,586	306	9,996	197	8,820	159	8,232	129	
50	0.005	12,096	284	10,080	236	9,072	186	8,568	120	7,560	97	7,056	78	
2.5	8	0.18	17,280	1,361	14,400	1,134	12,960	1,021	12,240	716	10,800	535	10,080	431
	12	0.18	17,280	1,134	14,400	1,020	12,960	933	12,240	644	10,800	520	10,080	387
	16	0.1	15,552	1,008	12,960	839	11,664	758	11,016	579	9,720	450	9,072	349
	20	0.1	15,552	840	12,960	794	11,664	711	11,016	515	9,720	450	9,072	310
	30	0.06	13,824	696	11,520	580	10,368	457	9,792	348	8,640	272	8,064	220
	40	0.03	12,096	437	10,080	364	9,072	328	8,568	250	7,560	196	7,056	158
50	0.01	12,096	375	10,080	338	9,072	304	8,568	203	7,560	171	7,056	138	
3	8	0.3	15,360	1,210	12,800	1,008	11,520	907	10,880	636	9,600	475	8,960	383
	12	0.21	15,360	1,210	12,800	1,008	11,520	907	10,880	636	9,600	475	8,960	383
	16	0.12	13,824	995	11,520	829	10,368	746	9,792	573	8,640	428	8,064	344
	20	0.12	13,824	895	11,520	787	10,368	705	9,792	573	8,640	428	8,064	344
	25	0.08	13,824	895	11,520	787	10,368	705	9,792	573	8,640	428	8,064	344
	30	0.08	13,824	796	11,520	663	10,368	601	9,792	573	8,640	428	8,064	310
	40	0.05	12,288	618	10,240	515	9,216	464	8,704	356	7,680	304	7,168	245
50	0.02	10,752	389	8,960	347	8,064	291	7,616	194	6,720	152	6,272	123	
4	12	0.4	11,500	2,070	9,400	1,692	8,460	1,370	7,990	1,222	7,050	811	6,580	654
	16	0.28	11,500	2,070	9,400	1,692	8,460	1,370	7,990	1,222	7,050	811	6,580	654
	20	0.28	10,350	1,863	8,460	1,522	7,614	1,233	7,191	1,099	6,345	730	5,922	588
	25	0.16	10,350	1,676	8,460	1,370	7,614	1,109	7,191	990	6,345	730	5,922	588
	30	0.16	10,350	1,676	8,460	1,370	7,614	1,109	7,191	880	6,345	649	5,922	588
	35	0.1	9,137	1,316	7,614	1,096	6,853	888	6,472	792	5,711	584	5,330	471
	40	0.1	9,137	1,151	7,614	959	6,853	777	6,472	693	5,711	511	5,330	412
50	0.06	7,896	789	6,580	658	7,106	592	5,593	460	4,935	309	4,606	249	
5	20	0.3	9,014	1,621	7,512	1,351	6,761	1,216	6,385	945	5,634	635	5,258	513
	25	0.3	8,112	1,458	6,760	1,215	6,084	1,094	5,746	850	5,070	571	4,732	461
	30	0.2	8,112	1,313	6,760	1,094	6,084	984	5,746	765	5,070	514	4,732	415
	40	0.15	7,301	1,052	6,084	876	5,476	788	5,171	613	4,563	412	4,259	332
	50	0.1	7,301	986	6,084	876	5,476	690	5,171	575	4,563	360	4,259	291
6	20	0.5	7,418	1,481	6,182	1,234	5,564	1,111	5,255	864	4,637	580	4,327	469
	30	0.4	6,744	1,346	5,620	1,122	5,058	1,010	4,777	785	4,215	527	3,934	426
	40	0.3	6,744	1,211	5,620	1,009	5,058	908	4,777	706	4,215	474	3,934	383
	50	0.2	6,000	981	5,000	817	4,500	735	4,250	636	3,750	427	3,500	345

※ a_p is shown as the criteria for Group 2 workpieces. For other groups, adjust the cutting depth according to the cutting depth factors in the above table.

- [Note]**
- ① PN coating is less electro conductive. Therefore, electric transmitted measuring systems may not work.
 - ② Use the appropriate coolant for the work material and machining shape.
 - ③ These Recommended Cutting Conditions indicate only the rule of a thumb for the cutting conditions. In actual machining, the condition should be adjusted according to the machining shape, purpose and the machine type.
 - ④ If the rpm of the machine is low, lower the feed rate also to put the rpm and feed rate in the same ratio.

Features

Dimensions
Ball/PN Coating

Dimensions
Ball/ATH Coating

Cutting condition
Ball/High efficiency

Cutting condition
Ball/High accuracy

Dimensions
Square/PN Coating

Dimensions
Square/ATH Coating

Cutting condition
Square/High efficiency

Cutting condition
Square/High accuracy

Technical Data

New PVD Technology

2 types of coatings to handle a variety of work materials.

Recommended machining areas for each coating

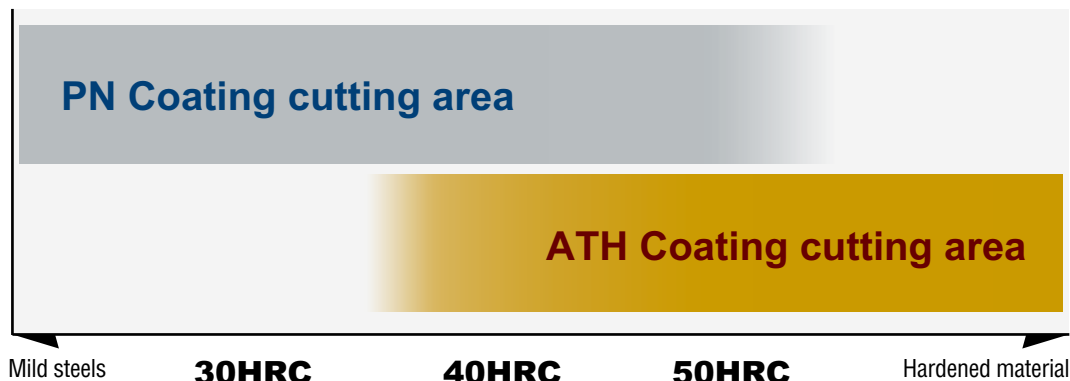

Cutting Data 1

Work material : **SCM440[®] 30HRC**
 Holder : HSK-F63
 Tool dia. : R0.5×Under neck 6mm
 Coolant : Air-blow
 $n=28,000\text{min}^{-1}$ ($v_c=88\text{m/min}$)
 $v_f=1,200\text{mm/min}$ ($f_z=0.02\text{mm/t}$)
 $a_p=0.036\text{mm}$ $a_e=0.108\text{mm}$ OH=18mm
 Cutting length 10m

PN Coating



ATH Coating



Cutting Data 2

Work material : **HPM-MAGIC 40HRC**
 Holder : HSK-F63
 Tool dia. : R0.5×Under neck 10mm
 Coolant : Air-blow
 $n=24,300\text{min}^{-1}$ ($v_c=76\text{m/min}$)
 $v_f=900\text{mm/min}$ ($f_z=0.018\text{mm/t}$)
 $a_p=0.04\text{mm}$ Cutting reciprocating slot.
 OH=18mm

PN Coating



ATH Coating



Cutting Data 3

Work material : **DAC[®] 45HRC**
 Holder : HSK-F63
 Tool dia. : R0.5×Under neck 6mm
 Coolant : Air-blow
 $n=27,540\text{min}^{-1}$ ($v_c=86\text{m/min}$)
 $v_f=1,115\text{mm/min}$ ($f_z=0.02\text{mm/t}$)
 $a_p=0.032\text{mm}$ $a_e=0.096\text{mm}$ OH=18mm
 Cutting length 10m

PN Coating



ATH Coating



Cutting Data 4

Work material : **HPM38 52HRC**
 Holder : HSK-F63
 Tool dia. : R0.5×Under neck 10mm
 Coolant : Air-blow
 $n=24,300\text{min}^{-1}$ ($v_c=76\text{m/min}$)
 $v_f=919\text{mm/min}$ ($f_z=0.018\text{mm/t}$)
 $a_p=0.016\text{mm}$ OH=18mm
 Cutting length 20m

PN Coating

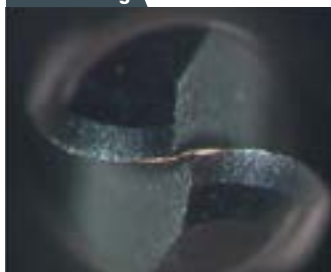

ATH Coating



Features

Dimensions
Ball/PN Coating

Dimensions
Ball/ATH Coating

Cutting condition
Ball/High efficiency

Cutting condition
Ball/High accuracy

Dimensions
Square/PN Coating

Dimensions
Square/ATH Coating

Cutting condition
Square/High efficiency

Cutting condition
Square/High accuracy

Technical Data

Technical data Ball nose



Enables high-accuracy stable machining with excellent surface quality.

EPDBE-PN

PN Coating

Technical Data **SCM440[Ⓜ] 33HRC rib slot evaluation**

Tool : EPDBE2010-10-PN (R0.5 Under neck10mm)

★This is amazing! Point 1 **Uniformity of machined surface**



**Forms uniform cutter marks.
No vibrations occurred.**

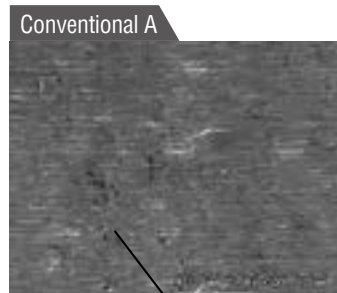

Cutter marks are not uniform.
In addition, friction has collapsed marks

Rib slot evaluation

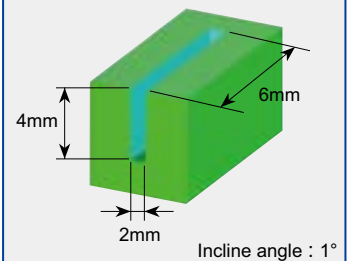

Work material : SCM440[Ⓜ] 33HRC
Holder : HSK-F63
Coolant : Wet
 $n=16,000\text{min}^{-1}$ ($v_c=50\text{m/min}$)
 $v_f=1,000\text{mm/min}$ ($f_z=0.03\text{mm/t}$)
 $a_p \times a_e=0.02\text{mm} \times 0.04\text{mm}$

★This is amazing! Point 2 **Low deflection provides improved machining accuracy!**

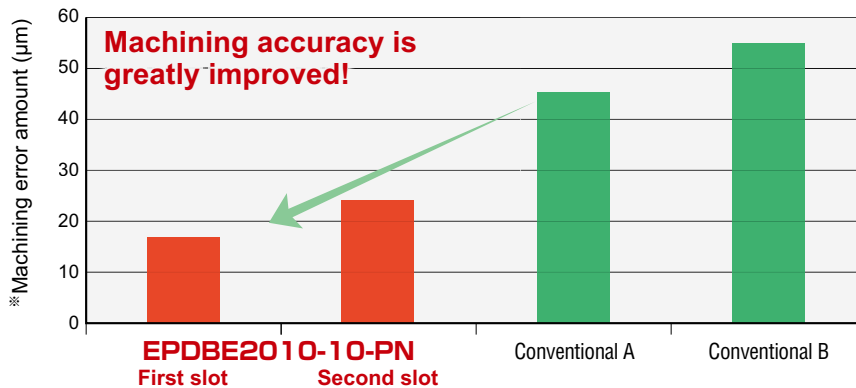

Machining accuracy is greatly improved!

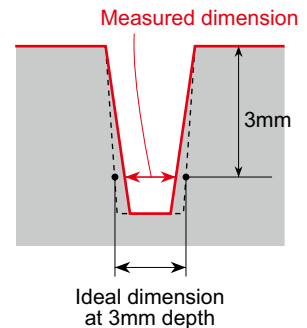

※Machining error amount::
(Ideal dimension)-(Measured dimension after cutting)

★This is amazing! Point 3 **Long life: Wear resistance plus good chipping resistance**



**Enables stable machining with no vibrations.
Good wear condition.**

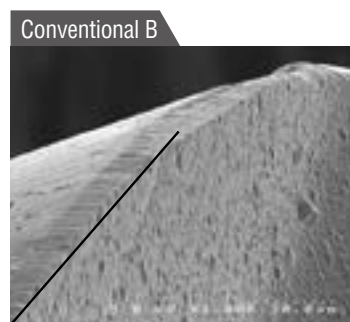
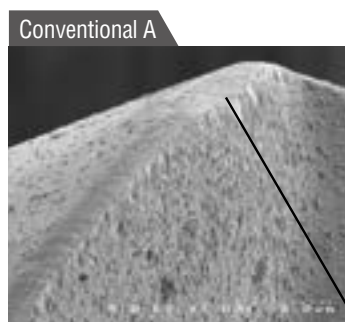

Wearing down of tip is fast.
Wear resistance is poor.

Features

Dimensions
Ball PN Coating

Dimensions
Ball ATH Coating

Cutting condition
Ball High efficiency

Cutting condition
Ball High accuracy

Dimensions
Square PN Coating

Dimensions
Square ATH Coating

Cutting condition
Square High efficiency

Cutting condition
Square High accuracy

Technical Data

Technical data Ball nose



Rely on ATH Coating for stable machining of even high-hardness materials!

EPDBE-ATH

ATH Coating

Technical Data

Tool : EPDBE2010-10-ATH (R0.5 Under neck10mm)

★This is amazing! Point 1 **Wear condition is stable. No chipping even on high-hardness materials.**

Machining shape	Cutting condition	EPDBE2010-10-ATH	Conventional
	Work material : SLD[Ⓜ] 60HRC Holder : HSK-F63 Coolant : Air Blow $n=10,000\text{min}^{-1}$ $(v_c=31.4\text{m/min})$ $v_f=800\text{mm/min}$ $(f_z=0.04\text{mm/t})$ $a_p \times a_e=0.02\text{mm} \times 0.02\text{mm}$	<p>Stable wear condition from chisel to outer perimeter</p>	<p>Chipping occurred</p>

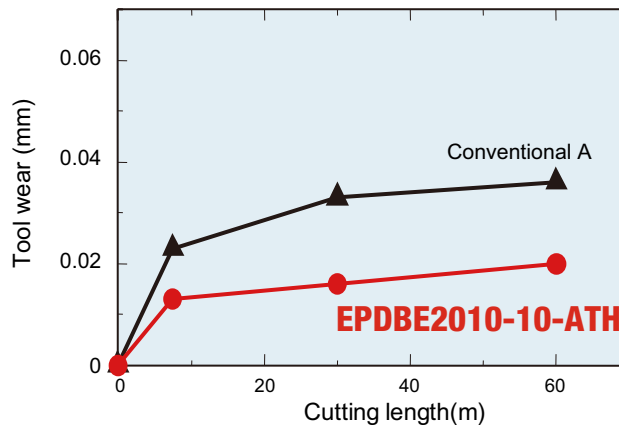

Technical Data

Tool : EPDBE2010-10-ATH (R0.5 Under neck10mm)

★This is amazing! Point 2 **High accuracy achieved due to little deflection.**

Machining shape	Cutting condition
	Work material : SUS420J2[Ⓜ] 52HRC Holder: HSK-F63 Coolant : Air Blow $n=16,000\text{min}^{-1}$ $(v_c=50\text{m/min})$ $v_f=1,000\text{mm/min}$ $(f_z=0.03\text{mm/t})$ $a_p \times a_e=0.02\text{mm} \times 0.02\text{mm}$ Incline angle : 1°

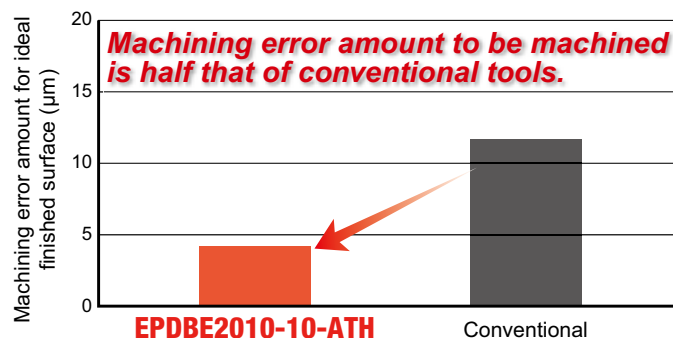

Machining error amount to be machined is half that of conventional tools.

EPDBE2010-10-ATH

Conventional

Periphery helix angle is strong, improving cutting performance.

Tool interference check, Re-grinding

Example of difference in neck interference area

Difference in interference area for R=0.3 x Under neck length=2mm

(Figures show a slope angle of 1°.)

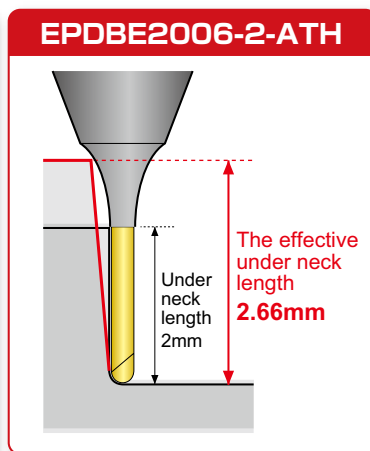
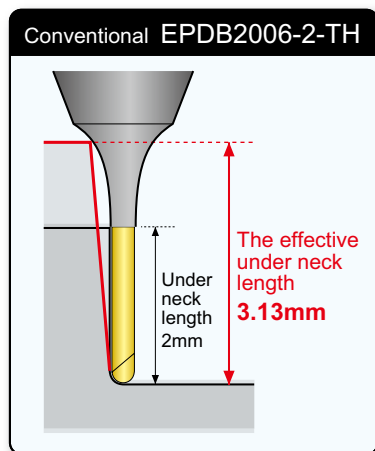

When a conventional product and new product with R=0.3 x Under neck length=2mm are compared for a surface with a 1° slope angle, the conventional EPDB2006-2-TH has an effective under neck length of 3.13mm, but for the new EPDBE2006-2-ATH, the effective under neck length is 2.66mm.

The improved neck shape used in these new products results in a different interference area than the EPDB and EPDS conventional models.

For checking interference:

CAD/CAM Support Data Pack

The CAD/CAM Support Data Pack has been updated to include the Epoch Deep Evolution Series. You can search for the latest end mill. Please visit our company's home page for details.



Re-grinding compatibility range table

Item code	Product name	Tool dia. (mm)	Shape	Re-grinding compatibility range (mm)	
				Outer dia.	End
EPDBE-PN	Epoch Deep Ball Evolution (PN Coating)	0.1~6		N/A	1~6
EPDBE-ATH	Epoch Deep Ball Evolution (ATH Coating)	0.1~6		N/A	1~6
EPDSE-PN	Epoch Deep Square Evolution (PN Coating)	0.1~6		6	2~6
EPDSE-ATH	Epoch Deep Square Evolution (ATH Coating)	0.1~6		6	2~6

[Note] Contact our sales office regarding whether or not regrinding is possible for tools where Under neck length/Tool diameter is 10 or greater.

特長

寸法ボールPN

寸法ボールATH

切削条件ボール高効率

切削条件ボール高精度

寸法スクエアPN

寸法スクエアATH

切削条件スクエア高効率

切削条件スクエア高精度

技術データ



The diagrams and table data are examples of test results, and are not guaranteed values.
 "MOLDINO" is a registered trademark of MOLDINO Tool Engineering, Ltd.



Attentions on Safety

1. Cautions regarding handling

- (1) When removing the tool from its case (packaging), be careful that the tool does not pop out or is dropped. Be particularly careful regarding contact with the tool flutes.
- (2) When handling tools with sharp cutting flutes, be careful not to touch the cutting flutes directly with your bare hands.

2. Cautions regarding mounting

- (1) Before use, check the outside appearance of the tool for scratches, cracks, etc. and that it is firmly mounted in the collet chuck, etc.
- (2) If abnormal chattering, etc. occurs during use, stop the machine immediately and remove the cause of the chattering.

3. Cautions during use

- (1) Before use, confirm the dimensions and direction of rotation of the tool and milling work material.
- (2) The numerical values in the standard cutting conditions table should be used as criteria when starting new work. The cutting conditions should be adjusted as appropriate when the cutting depth is large, the rigidity of the machine being used is low, or according to the conditions of the work material.
- (3) Cutting tools are made of a hard material. During use, they may break and fly off. In addition, cutting chips may also fly off. Since there is a danger of injury to workers, fire, or eye damage from such flying pieces, a safety cover should be attached when work is performed and safety equipment such as safety goggles should be worn to create a safe environment for work.
- (4) There is a risk of fire or inflammation due to sparks, heat due to breakage, and cutting chips. Do not use where there is a risk of fire or explosion. **Please caution of fire while using oil base coolant, fire prevention is necessary.**
- (5) Do not use the tool for any purpose other than that for which it is intended.

4. Cautions regarding regrinding

- (1) If regrinding is not performed at the proper time, there is a risk of the tool breaking. Replace the tool with one in good condition, or perform regrinding.
- (2) Grinding dust will be created when regrinding a tool. When regrinding, be sure to attach a safety cover over the work area and wear safety clothes such as safety goggles, etc.
- (3) This product contains the specified chemical substance cobalt and its inorganic compounds. When performing regrinding or similar processing, be sure to handle the processing in accordance with the local laws and regulations regarding prevention of hazards due to specified chemical substances.

MOLDINO Tool Engineering, Ltd.

Head Office
 Hulic Ryogoku Bldg. 8F, 4-31-11, Ryogoku, Sumida-ku, Tokyo, Japan 130-0026
 International Sales Dept. : TEL +81-3-6890-5103 FAX +81-3-6890-5128

Official Web Site

<http://www.moldino.com/en/>

Database for selection Cutting Tool Products **[TOOL SEARCH]**

Europe	MOLDINO Tool Engineering Europe GmbH Itterpark 12, 40724 Hilden, Germany, Tel +49-(0)2103-24820 Fax +49-(0)2103-248230
China	MOLDINO Tool Engineering (Shanghai), Ltd. Room 2604-2605, Metro Plaza, 555 Loushanguan Road, Changning District, Shanghai, 200051, China Tel +86-(0)21-3366-3058 Fax +86-(0)21-3366-3050
America	MITSUBISHI MATERIALS U.S.A. CORPORATION DETROIT OFFICE Customer service 41700 Gardenbrook Road, Suite 120, Novi, MI 48375-1320 U.S.A. Tel +1(248) 308-2620 Fax +1(248) 308-2627
Mexico	MMC METAL DE MEXICO, S.A. DE C.V. Av. La Cañada No.16, Parque Industrial Bernardo Quintana, El Marques, Querétaro, CP 76246, México Tel +52-442-1928600

Brazil	MMC METAL DO BRASIL LTDA. Rua Cincinnati Braga, 340 13° andar, Bela Vista – CEP 01333-010 São Paulo – SP., Brasil Tel +55(11)3506-5600 Fax +55(11)3506-5677
Thailand	MMC Hardmetal (Thailand) Co.,Ltd. MOLDINO Division 622 Emporium Tower, Floor 22/1-4, Sukhumvit Road, Klong Tan, Klong Toei, Bangkok 10110, Thailand TEL:+66-(0)2-661-8175 FAX:+66-(0)2-661-8176
India	MMC Hardmetal India Pvt Ltd. H.O.: Prasad Enclave, #118/119, 1st Floor, 2nd Stage, 5th main, BBMP Ward #11, (New #38), Industrial Suburb, Yeshwanthpura, Bengaluru, 560 022, Karnataka, India. Tel +91-80-2204-3600

DISTRIBUTED BY: